

ULTIMA series **undercounter**
labware washing systems

LANCER
GETINGE GROUP



Effective. Sustainable. Space efficient.



Clean one time, every time.

Offering the best labware cleaning solutions in the industry.

ULTIMA series washers offer the best labware cleaning solutions in the industry. From quality control to general laboratory research, Lancer ULTIMA series washers deliver high performance in a compact footprint. High density loading demands fewer cycles. Efficient use of water, detergents and rinsing agents minimizes the environmental impact. Energy saving construction lowers total cost of ownership.

The exclusive Prolux programmable microprocessor controller commands a full range of prewash, wash, rinse and drying functions through simple touchscreen menus on all ULTIMA series washers. The convenience of four preset programs for light to heavy loads simplifies operation, while more complex programs can be customized whenever needed to meet specific applications.

Washer Function and Flexibility



4 Factory Preset Programs
light, moderate, normal, heavy
and dozens more as desired



Lancer model 815 LX undercounter labware washer, shown with accessory loading racks, sold separately.



Prolux programmable microprocessor controller with intuitive touchscreen graphic user interface, alarm and monitoring, data capture and communications document cycle performance.

Stainless steel top and bottom spray arms and two levels of injection washing ensure thorough spray coverage.

High efficiency powerful fluid circulation with direct fluid path and rear manifold connections deliver optimal pressure and flow rates.

The high performance, high temperature cleaning process is managed with preset or user defined programmable cycles.

Injector jet performance provides inside out wash and rinse functions.

Two integrated automatic chemical dosing pumps are standard on all models.



View-In-Process Window

An optional View-In-Process (VIP) window includes an interior LED light for visual verification of the interior load during the cycle.

Lancer model 820 LX undercounter labware washer, shown with accessory loading rack, sold separately.

Less noise, less surface heat and less space required. **Because, less is more.**

Lancer ULTIMA series washers offer an ideal combination of precision engineering, efficient loading design and comprehensive controls required to process and document labware washing cycles. Lancer ULTIMA series models are ideal for installation under casework or freestanding placement. The compact footprint minimizes floor space and maximizes valuable research space.



Quiet Operation.
Noise reduction design minimizes sound for quiet operation.



Cool Surface.
High-performance insulation contains heat and limits energy consumption.



810 LX Features

- 4 Preset Cycles
- Programmable Cycles
- No Drying
- Additive Level Sensor (optional)



815 LX Features

- 4 Preset Cycles
- Programmable Cycles
- Forced-air Drying
- Additive Level Sensor (optional)



820 LX Features

- 4 Preset Cycles
- Programmable Cycles
- Forced-air Drying, Injectors, HEPA Filtered
- On Board Chemical Storage
- Additive Level Sensor

Models shown with optional View-In-Process (VIP) window.

Three options, **compact** footprints.

810 LX / 815 LX

Drawings display top, front and side of unit, with door swing allowance.

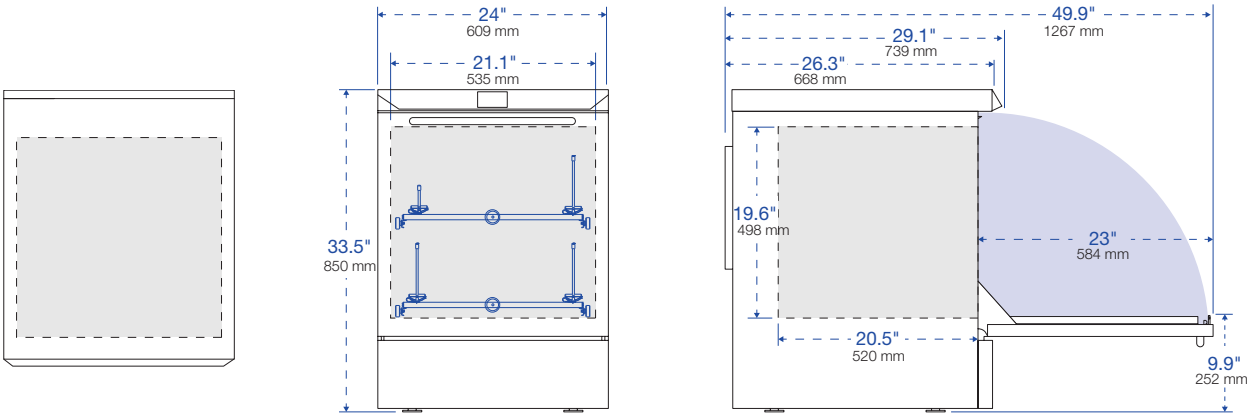

Model	Specifications							
	Interior Dimensions W x H x D	Exterior Dimensions W x H x D	Water Per Fill* gal (L)	Programs presets custom		120V 1-phase	208V 1-phase	208V 3-phase
810 LX	21.1" x 19.6" x 20.5" 535 x 498 x 520 mm	24" x 33.5" x 29.1" 609 x 850 x 739 mm	3.1 (12)	4	36	—	<input type="checkbox"/>	<input checked="" type="checkbox"/>
815 LX	21.1" x 19.6" x 20.5" 535 x 498 x 520 mm	24" x 33.5" x 29.1" 609 x 850 x 739 mm	3.1 (12)	4	36	<input type="checkbox"/>	<input type="checkbox"/>	<input checked="" type="checkbox"/>
820 LX	21.1" x 19.6" x 20.5" 535 x 498 x 520 mm	35.8" x 33.5" x 29.1" 909 x 850 x 739 mm	3.1 (12)	4	36	—	<input type="checkbox"/>	<input checked="" type="checkbox"/>

* Because Lancer calculates total water consumption per fill based on reservoir sump and all fluid path fill volumes, care should be taken when evaluating comparative water consumption claims.

820 LX

Drawings display top, front and side of unit, with door swing allowance.

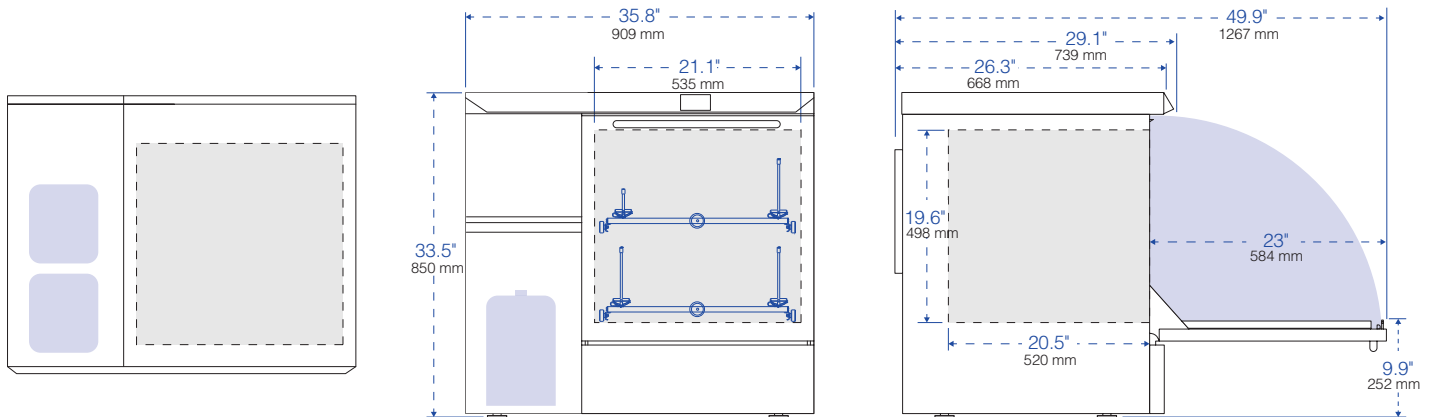

Model	Cycle Function				Chemical Dosing				Net Weight
	Wash Temp. max. °C/°F	Rinse purified water	Rinse acid	Drying	Automatic	On-Board chemical storage	Level Sensors	Water Softener	Empty lb (kg)
810 LX	95°C / 203°F	■	■	—	■	—	□	—	187 (85)
815 LX	95°C / 203°F 85°C / 185°F (on 120V unit)	■	■	forced-air chamber	■	—	□	—	187 (85)
820 LX	95°C / 203°F	■	■	forced-air chamber and injectors; HEPA filtered	■	■	■	■	254 (115)

■ / □ Standard / Optional Features



World class engineering, robust construction for safety and efficiency.

Ergonomic Loading Configurations.

- Telescoping load-bearing rails permit extension of racks for easy loading.
- All racks are interchangeable between top and bottom wash levels, and among Lancer ULTIMA series freestanding models 910 LX, 1300 LX and 1800 LX. This minimizes the need for additional accessories.
- The fold-down door creates a platform for proper rack positioning and more comfortable loading and unloading.



Wash Load Configurations

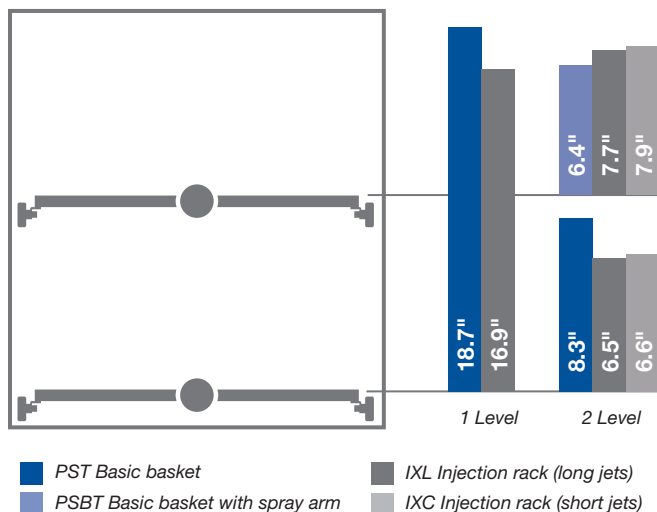

Cleaning Performance and Safety. Operating systems are designed for performance, efficiency and high throughput.

- An automatic door lock prevents door opening during active cycles; protects the user from heat and chemical exposure.
- Top and bottom stainless steel spray arms are pressurized to provide exterior coverage to the labware.
- Injector rack manifold connections are located at the rear for proper alignment and the most efficient pressure and flow.
- Washing temperature can be set to a maximum of 95°C (203°F) if required for more difficult soils (85°C for 120V unit).
- Automatic Peristaltic pumps are self-contained for accurate and repeatable dosing of detergents or acids required by each cycle.
- Multiple DI rinses can be programmed to eliminate interior and exterior spotting.

Alarms and Monitoring.

- The 3.5" high resolution touchscreen color display is easy to read from a distance and saves steps when monitoring.
- The intuitive graphic user interface creates a series of visual performance indicators such as active program, time remaining, warning, alarm and cycle completed functions.
- Four preset programs permit one touch operation. Additional cycles are programmed from the graphic user interface.
- An integrated USB port allows easy front panel access for process tracking and data logging. Optional process record printouts available through USB or Ethernet ports are managed by the Prolux controller.

Hydraulic Design

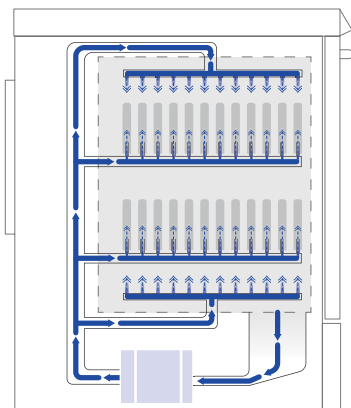

The Lancer hydraulic design optimizes pressure and flow for efficient performance at all wash levels.

The combination of a high performance recirculation pump, straight-line fluid path and center-mounted rack interface assures maximum water flow through spray arms and injectors.

Washer pump is protected from debris by a stainless steel sump screen. The screen lifts out without tools for easy cleaning.

Construction. The sump, spray arms, interior chamber and door are fabricated from 304L and 316L stainless steel to resist aggressive chemicals and residues.

- Exterior 304L stainless steel panels resist corrosion, simplify cleaning and protect electrical and plumbing components.
- Cabinet fits in 24" wide (610 mm) casework opening for new and replacement installation (810 LX and 815 LX models only).
- A steam condenser minimizes water vapor during heated cycles to protect casework from moisture damage.
- Precut utility panels on sides and rear simplify installation.
- Double-wall insulated assembly confines heat loss and minimizes noise.
- Easy access stainless steel chamber filters extend washer life by protecting pumps and interior plumbing from debris.
- A compact liquid sump and direct fluid path minimizes water volume per fill, lowers overall consumption per cycle and improves sustainability throughout the useful life.

View-In-Process

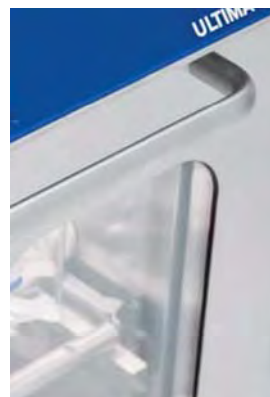

An optional 13.7" (348 mm) H x 6.8" (173 mm) W dual pane View-In-Process (VIP) window includes an interior LED light for visual verification of the interior load during the cycle. The light is activated by the On/Off switch through the Prolux controller. Tempered safety glass provides excellent sound and heat abatement and enhances operator safety. Factory installed, specify when ordering.

One-touch simplicity, limitless flexibility.

Prolux Controller. The Prolux controller is based on a high-performance PLC microprocessor designed for simplicity, one-touch start, real-time status indicators and intuitive programming options that permit customization over the range of washer operations.

Prolux integrates a suite of menu screens that support digital functions from cycle selection, process monitoring, warning advisories, audible and visual alarms, system communications and data capture.

Operation.

- Screen menus and a graphic user interface are designed to simplify setup and operations including active program, remaining time, warnings, alarms and complete cycle notifications.
- Four preset programs are factory loaded for one-touch control of most routine applications.
- When additional cycle programs are desired, parameters can be changed through secure access to the administration screen where an intuitive graphic user interface displays all options.

Communication and Connectivity.

- A front-panel USB port simplifies direct connection to peripheral devices for cycle tracking and data capture. The port complies with international IP21 standards for ingress protection from condensation.
- A real-time process record is printed if optional printer is installed.
- Multiple data ports include Ethernet and RS422/485 connectors.
- Impact or network printers options document cycle performance, warnings and alarms.



810 LX / 815 LX / 820 LX



- 3.5" color touchscreen interface
- 320 x 240 pixel resolution display
- four presets
- additional custom program options



The Prolux PLC Controller includes a touchscreen interface with a common icon directory that permits scrolling access to primary screens from the same menu. A set of sub-menu screens display additional icon directories specific to the screen functions.

Programming.

Programmable cycle parameter selections include:

- **Prewash.** Up to 3 prewashes, 0 to 30 minutes each, temperatures up to 95°C* (203°F)*, chemical dosing as desired.
- **Wash.** 0 to 30 minutes, temperatures up to 95°C* (203°F)*, chemical dosing as desired.
- **Acid rinse.** 0 to 30 minutes chemical dosing, temperatures up to 95°C* (203°F)*.
- **Running Water Rinses.** One or more short rinse sequences after the wash or rinse cycle purge the hydraulic circuit of residual detergent and rinsing agents.
- **Rinse, DI.** Up to 4 rinses, 0 to 30 minutes each. Ambient to 95°C* (203°F)*.
- **Final Rinse, DI.** 0 to 30 minutes, temperatures up to 95°C* (203°F)*.
- **Drying.** Model 810 LX, fixed. Model 815 LX, temperature 110°C (203°F)* and time fixed. Model 820 LX, adjustable temperature ambient to 110°C (203°F)*, time adjustable.
- **Cooling.** Model 810 LX, fixed. Models 815 LX and 820 LX, time adjustable.

*Up to 85°C (185°F) on 120V models.

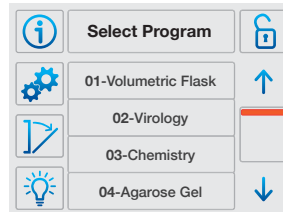

• **Program Selection.** The Program Selection screen lists the four factory presets, as well as additional presets added through administrator access.

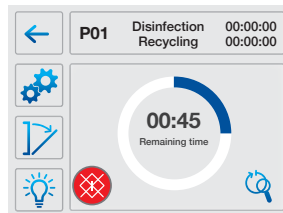

• **Cycle in Process.** A real-time status screen displays time remaining until cycle completion and links to cycle detail screens with the touch of a button.

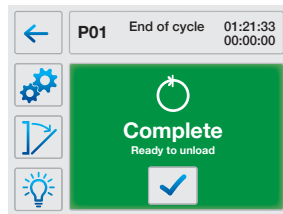

• **Cycle Completed.** The green Cycle Completed screen confirms completion of the cycle and indicates the washer is safe to unload.

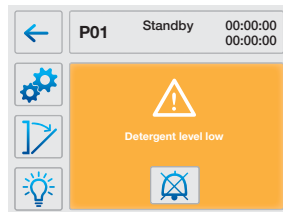

• **Warning Message.** The amber Warning Message screen provides a status report to prompt refill of detergent and rinse agents.

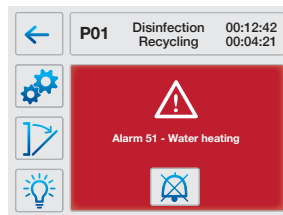

• **Alarm Message.** The red Alarm Message screen confirms the reason for a system shutdown and prompts corrective action needed in advance of a restart.

Expert guides, **effective solutions.**

Site Preparation and Utilities.

Pre-Installation. Lancer start-up services by factory-authorized technicians include washer set and leveling, pre-installation and final inspections, soft hook-up to utilities (in place by customer), check-out and initial operation. Contact Lancer to arrange startup services. Validation documentation and execution options are available; contact Lancer for information. See options.

Post-Installation. Lancer offers technical support by direct product specialists between 8AM and 7PM Eastern Time EST.

Warranty Information. Lancer products are supported by a standard industry warranty.

Lancer Model	810 LX / 815 LX / 820 LX
Water Supply (hot, cold and DI)	¾" hose thread connection, recommended min. flow 5.25 gpm (20 L); lower flow rates may extend cycle times; 29-87 psi water pressure
Drain Requirement, Vertical Standpipe	1 ½" (40 mm) diameter, 20" to 27" (500 to 700 mm) above floor

Certifications

UL/IEC 61010-1





Enhancements for your unique application.

Options

		810 LX	815 LX	820 LX
Discharge Water Cooling	Reduces effluent temperature to less than 60°C for code compliant transfer to utility drain.	<input type="checkbox"/>	<input type="checkbox"/>	<input type="checkbox"/>
pH Programming	Neutralizes effluent before transfer to utility drain.	<input type="checkbox"/>	<input type="checkbox"/>	<input type="checkbox"/>
Low Pressure Kit	Boosts DI water supply input pressure to assure optimum performance.	<input type="checkbox"/>	<input type="checkbox"/>	<input type="checkbox"/>
Liquid Level Sensor	Indicates low volume in detergent and acid additive reservoirs.	<input type="checkbox"/>	<input type="checkbox"/>	<input checked="" type="checkbox"/>
External Printer, Externally Mounted	Installs by direct connection to washer port. Generates 2.25" (57 mm) thermal strip record of washer function.	<input type="checkbox"/>	<input type="checkbox"/>	<input type="checkbox"/>
Base Cabinet	Stainless steel cabinet sized to accommodate models 810 LX and 815 LX, or model 820 LX. Elevates washer loading platform by 20" (508 mm) to improve ergonomic access when undercounter installation is not desired.	<input type="checkbox"/>	<input type="checkbox"/>	<input type="checkbox"/>
IQ/OQ Validation	Includes documentation verification, review of accessories/options, review of equipment installation, verification of utility supplies, review of access levels, review of configuration settings, I/O testing, functional testing, alarm testing and a complete cycle test.	<input type="checkbox"/>	<input type="checkbox"/>	<input type="checkbox"/>
Conductivity Verification	Conductivity verification of final rinse quality.	<input type="checkbox"/>	<input type="checkbox"/>	<input type="checkbox"/>
View-In-Process Window	 Includes interior light, permitting visual verification during wash cycles.	<input type="checkbox"/>	<input type="checkbox"/>	<input type="checkbox"/>

/ Standard / Optional Features

See product specifications for details and additional options to select.

Accessories

Choose from up to 60 different injector racks, pipette racks and baskets. All racks are interchangeable between the washer lower and upper levels.

- A wide variety of standard inventory baskets and injector racks are available to meet most needs.
- Custom racks and baskets can be fabricated to meet specific needs or special applications.

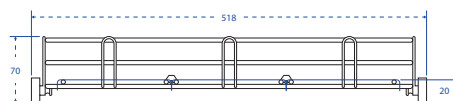

Basic Basket with reversible tray lid:
Catalog No. PST and GC



Basic basket with spray arm: Catalog No. PSBT



Basket for culture dishes: Catalog No. BP

Baskets

Useful for beakers, trays, dishes, dissolution vessels, funnels, instruments and jars.

	810 LX / 815 LX / 820 LX
Basic basket	PST
Basic basket with spray arm	PSBT
Basket, half with spray arm	PSBT 1/2
Basket, for culture dishes	BP

Basket Covers

Accessory basket covers are available to secure small or lightweight labware during the wash cycle.

	810 LX / 815 LX / 820 LX
Reversible tray lid for PST/PSBT	GC
Reversible tray lid, half size, for PST/PSBT	GC 1/2
Reversible tray lid, one-third size for PST/PSBT	GC 1/3

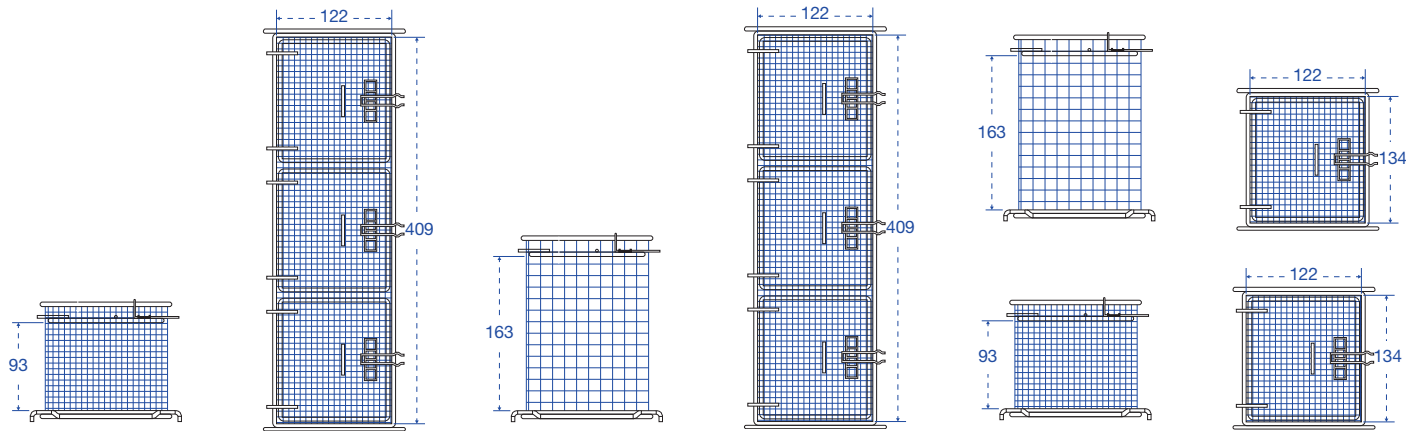

Small mesh basket with cover, long:
Catalog No. STCXL



Small mesh basket, tall with cover, long:
Catalog No. LTCXL



Small mesh baskets, tall and short:
Catalog No. LTC and STC

Small Mesh Baskets

For bottle caps, ferrules, plugs, stoppers
and test tubes.

	810 LX / 815 LX / 820 LX
Mesh basket, short, with cover, 122 x 134 x 93 mm	STC
Mesh basket, short, with cover, 122 x 409 x 93 mm	STCXL
Mesh basket, tall, with cover, 122 x 134 x 163 mm	LTC
Mesh basket, tall, with cover, 122 x 409 x 163 mm	LTCXL



Short Injectors, 3" (76 mm) tall

For inside out cleaning of narrow neck glassware, bottles, cylinders, boiling flasks, Erlenmeyer flasks and volumetric flasks.

	810 LX / 815 LX / 820 LX
Half rack, 27 short jets, 6 mm diameter	27 IXC 1/2
36 short jets, 6 mm diameter	36 IXC
48 short jets, 2 mm diameter	48 IXA
48 short jets, 6 mm diameter	48 IXC
64 short jets, 2 mm diameter	64 IXA
64 short jets, 6 mm diameter	64 IXC
64 short jets, mixed 2 mm and 6 mm diameter	64 IXA/2
100 short jets, 2 mm diameter	100 IXA
100 short jets, 6 mm diameter	100 IXC
100 short jets, mixed 2 mm and 6 mm diameter	100 IXA/2



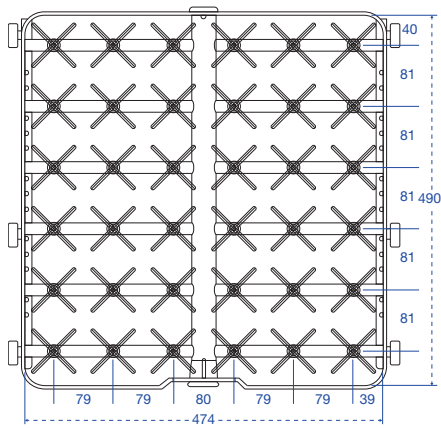

Catalog No. 36 IXC

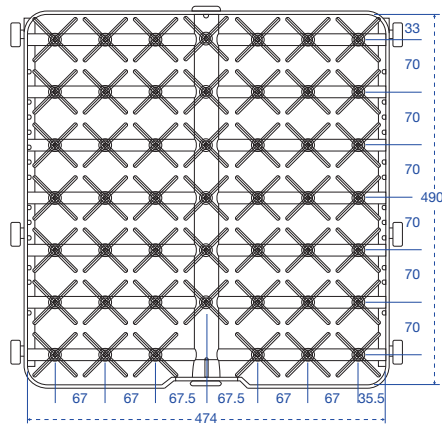

Catalog No. 48 IXC; IXA

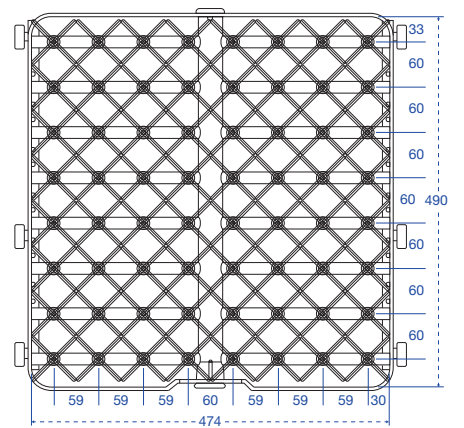

Catalog No. 64 IXA; IXC; IXA/2

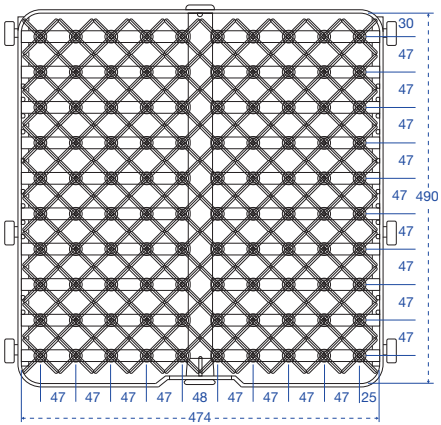
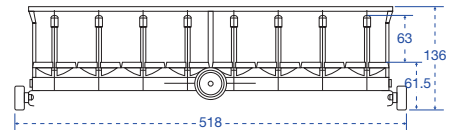
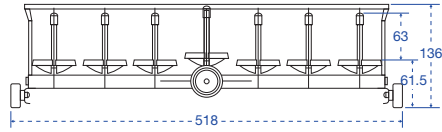
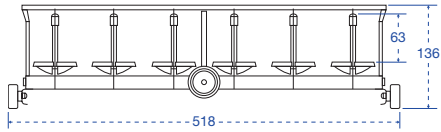

Catalog No. 100 IXA; IXC; IXA/2



IXC: Injector rack, short injectors, 3" (76 mm) tall, jets 6 mm diameter



IXA: Injector rack, short injectors, 3" (76 mm) tall, jets 2 mm diameter

Long Injectors, 6" (152 mm) tall

For inside out cleaning of large narrow neck glassware, bottles, cylinders, boiling flasks, Erlenmeyer flasks and volumetric flasks.

	810 LX / 815 LX / 820 LX
5 long jets, 12.7 mm diameter, with spray ball	5 IXL
9 long jets, 12.7 mm diameter	9 IXL
12 long jets, 6 mm diameter	12 IXL
20 long jets, 8 mm diameter	20 IXL
36 long jets, 6 mm diameter	36 IXL
48 long jets, 6 mm diameter	48 IXL
64 long jets, 6 mm diameter	64 IXL
100 long jets, 6 mm diameter	100 IXL

Injector Rack Covers

Injector rack covers are available to secure small or lightweight labware during the wash cycle.

	810 LX / 815 LX / 820 LX
Full-size	GCI
Half-size	GCI 1/2
Third-size	GCI 1/3

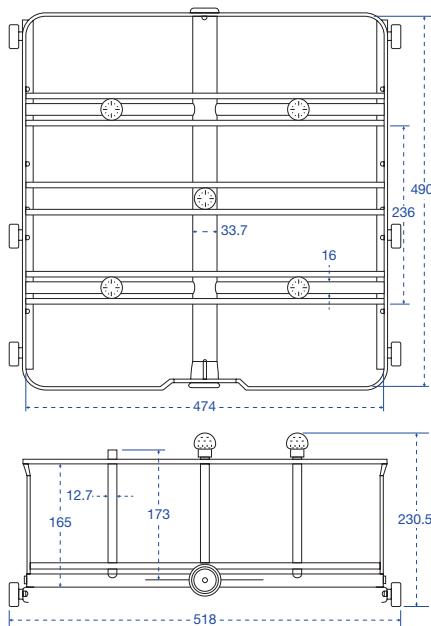

Catalog No. 5 IXL

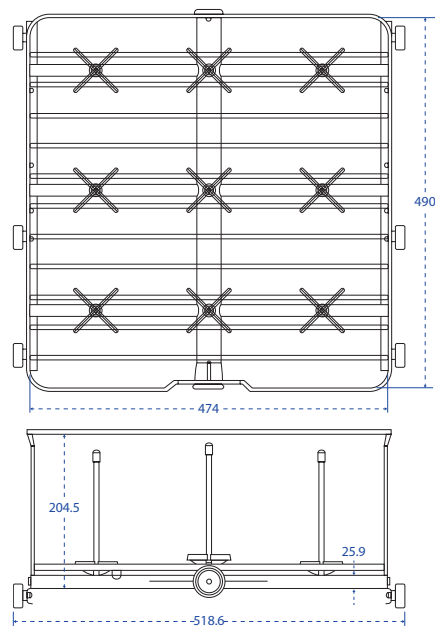

Catalog No. 9 IXL



Adjustable clip positions labware on injector to protect labware from breakage.

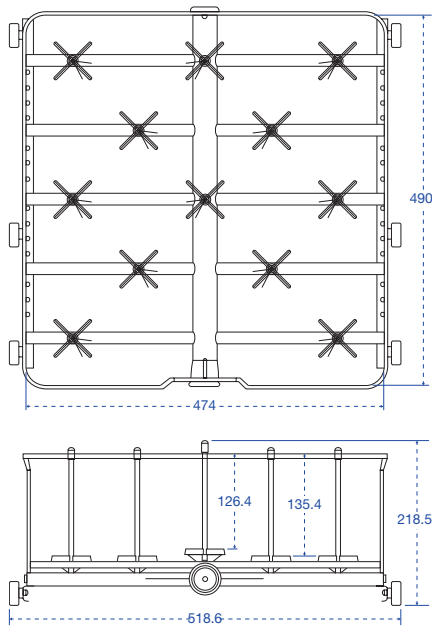

Catalog No. 12 IXL

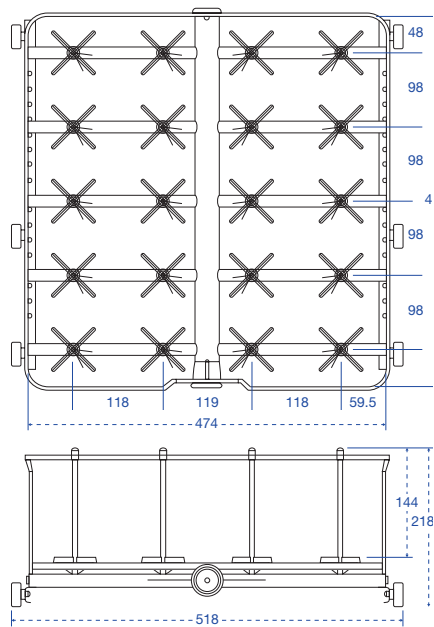

Catalog No. 20 IXL

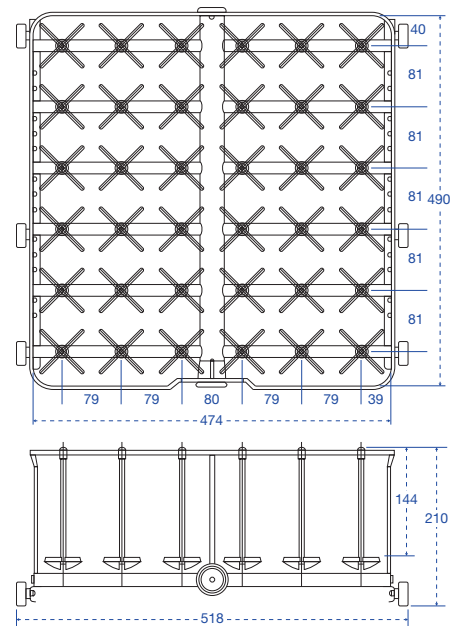

Catalog No. 36 IXL

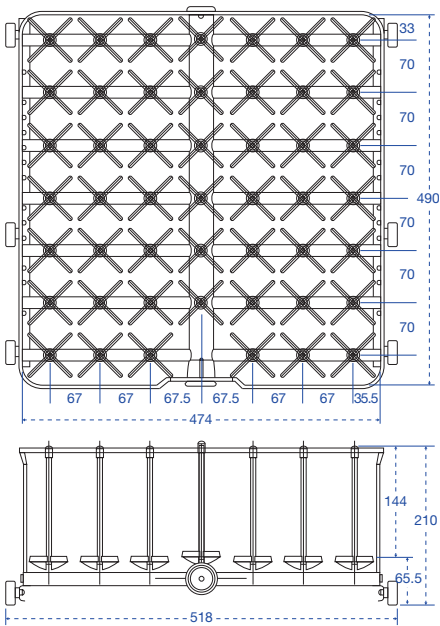

Catalog No. 48 IXL

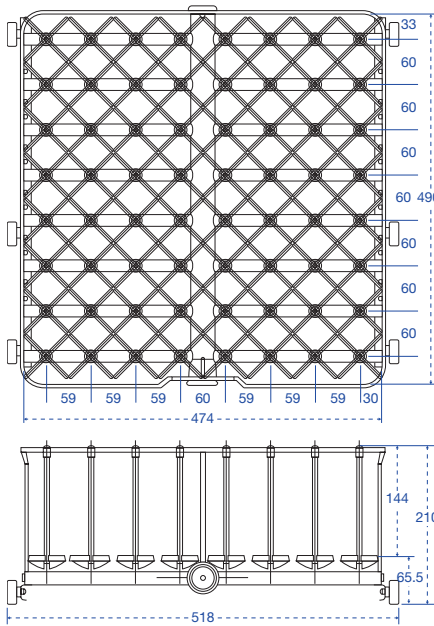

Catalog No. 64 IXL

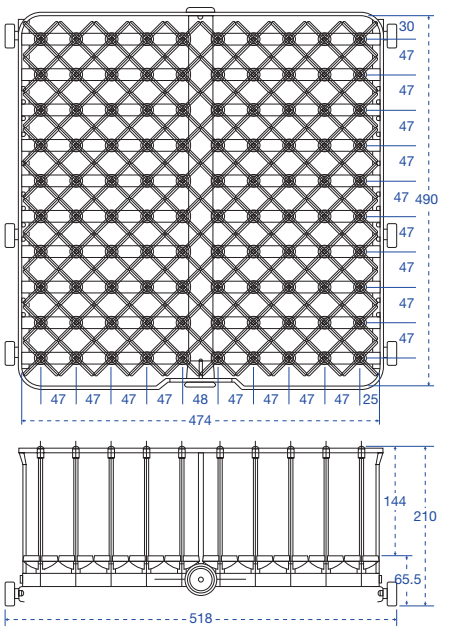

Catalog No. 100 IXL

Extra Long Injectors, 12" (305 mm) tall

For inside out cleaning of narrow neck glassware, bottles, cylinders, boiling flasks, Erlenmeyer flasks and large volumetric flasks.

	810 LX / 815 LX / 820 LX
1 long jet, 12.7 mm diameter, with spray ball	1 IXL
2 long jets, 12.7 mm diameter, with spray ball	2 IXL
4 long jets, 12.7 mm diameter, with spray ball	4 IXL

Combination Short/Long Injectors

For inside out cleaning of mixed loads of narrow neck glassware, bottles, cylinders, boiling flasks, Erlenmeyer flasks and volumetric flasks.

	810 LX / 815 LX / 820 LX
36 short and long jets, 6 mm diameter	36 IXLC
48 short and long jets, 6 mm diameter	48 IXLC
48 short and long jets, 6 mm diameter, 2 rows 2 mm diameter	48 IXLCA
64 short and long jets, 6 mm diameter	64 IXLC
100 short and long jets, 6 mm diameter	100 IXLC

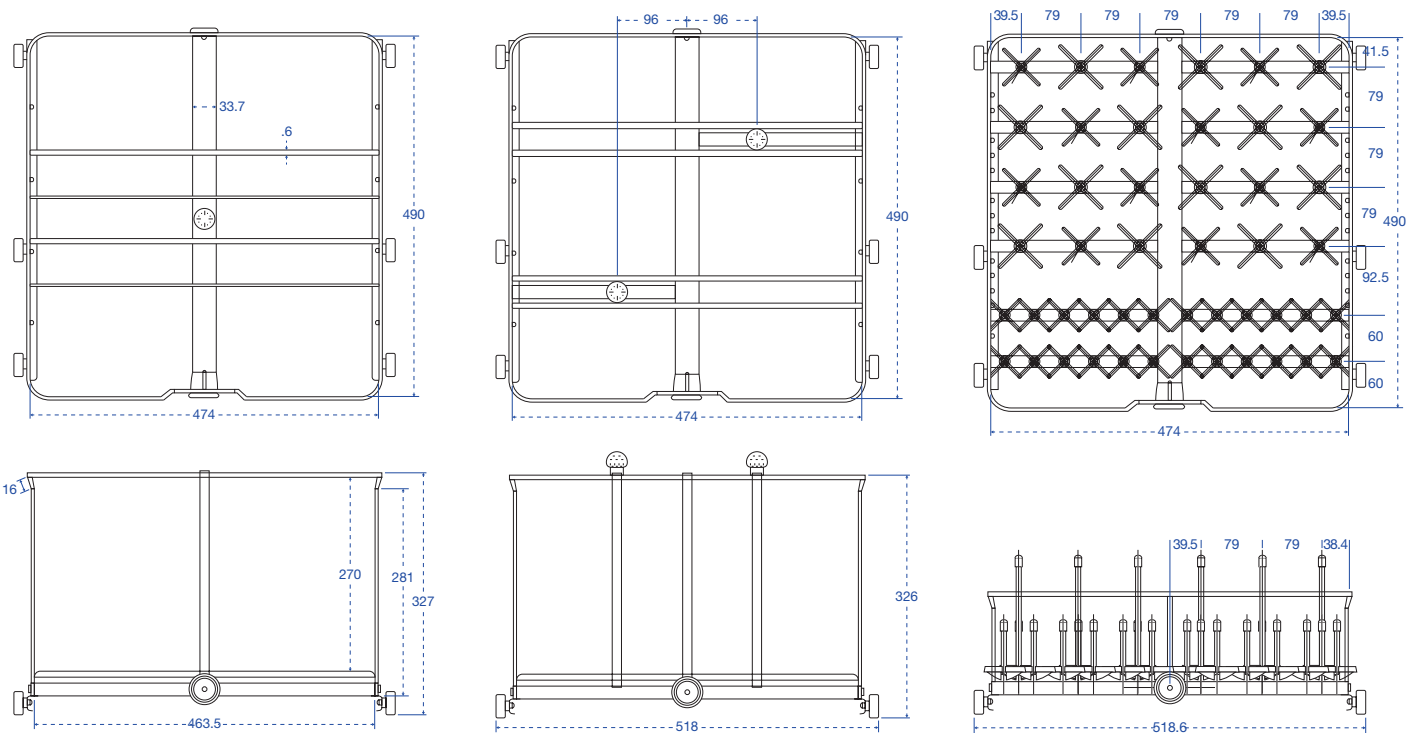

Catalog No. 1 IXL

Catalog No. 2 IXL

Catalog No. 48 IXLCA

Multipurpose Racks

For a combination of labware and pipettes.

	810 LX / 815 LX / 820 LX
Basic basket plus 27 short and long jets	PS/27 IXLC
25 pipettes, angled plus 24 short and long jets	25 PIP/24 IXLC
PST plus 14 short jets plus 4 long injectors, angled and perforated	4 EP/14 IXC/PS
28 short and long jets plus 4 long injectors, angled and perforated	4 EP/28 IXLC
50 pipettes plus 34 short and long jets	50PIP/34 IXLC
One third PS plus 21 short and long jets, plus 25 pipettes	PS/21 IXLC/25PIP

Pipette Racks

Accessory pipette racks are configured to accommodate reusable pipettes.

	810 LX / 815 LX / 820 LX
Grommet style, individually loaded, 100 position	100 PIP

Storage Stand

An accessory storage stand offers a convenient place to store accessory racks and baskets when not in use.

	810 LX / 815 LX / 820 LX
Holds up to 5 racks	RP

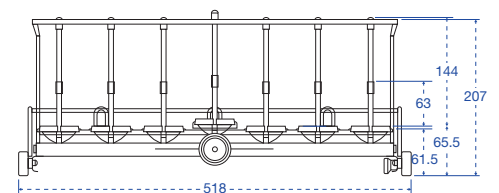
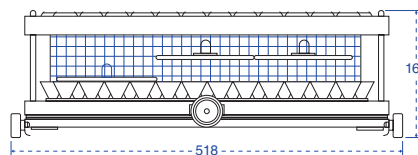
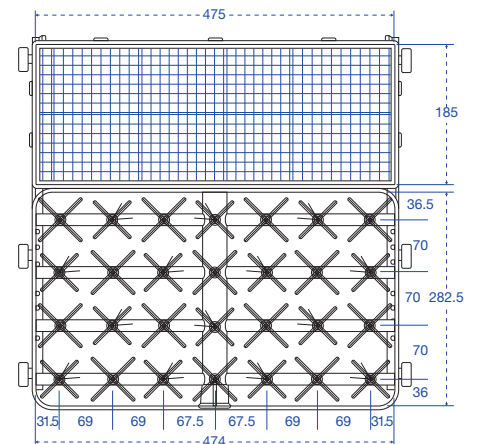
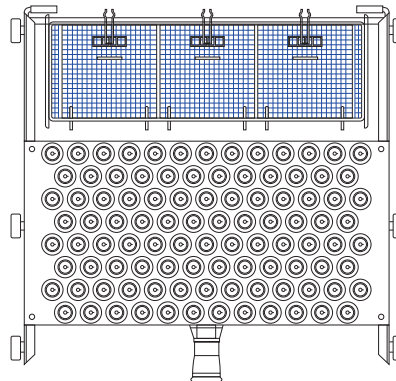

Catalog No. 100 PIP

Catalog No. PS/27/IXLC

Count on **quality.**

Customer Service. Lancer offers a range of customer services before, during and after installation. These include technical service and support, preventive maintenance plans and operator training and education. Contact Lancer for details.

Detergents and Rinsing Agents. For best results Lancer offers a selection of detergents and rinse agents formulated to maximize the performance of the Lancer labware washer while minimizing water consumption. Available exclusively from Lancer, these cleaning chemicals are made specifically for use in high pressure washers. To order call 407-327-8488 or contact chemsales@lancer.com.

- LancerClean Detergent is available in three solutions formulated for cleaning all different types of contaminants including laboratory soils, “baked on” organic residues, petroleum applications and other hard to clean soils. LancerClean is ideal for cleaning glassware, surgical instruments and many other labware items.

LCD-P is a potassium hydroxide based solution that provides excellent cleaning results for all types of contaminants and standard laboratory soils. It is recommended for use in all glassware washers.

LCD-S is a sodium hydroxide based solution specifically formulated to provide exceptional cleaning for the most difficult types of contaminants.

LCD-H is a low pH detergent comprised of a sodium silicate solution.

- LancerAcid Rinse is available in three formulas to meet specific cleaning requirements. Used as a rinsing agent following LancerClean detergent in the wash cycle, LancerAcid provides excellent results following washing of standard laboratory soils, organics, pharmaceutical based contaminants, petroleum and other difficult materials.

LCD-A is an acetic acid based neutralizing solution. It is the most commonly used rinsing agent.

LCD-C is an excellent rinsing agent with a citric acid based solution.

LCD-P is a phosphoric acid solution.

Lancer Freestanding Labware Washers. Lancer offers an expanded line of higher volume labware washers available in five sizes, each with optimized interior loading arrangements to improve throughput, enhance energy efficiency and reduce water consumption. Contact Lancer for details.

ULTIMA series labware washers

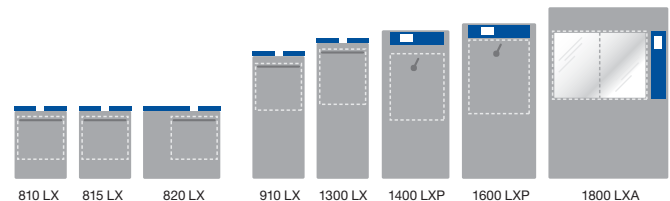

LANCER
GETINGE GROUP

1150 Emma Oaks Trail, Suite 140
Lake Mary, FL 32746 USA
Phone: +1 407.327.8488

www.lancer.com

GETINGE GROUP

Getinge Group is a leading global provider of innovative solutions for operating rooms, intensive-care units, hospital wards, sterilization departments, elderly care and for life science companies and institutions. With a genuine passion for life we build quality and safety into every system. Our unique value proposition mirrors the continuum of care, enhancing efficiency throughout the clinical pathway. Based on our first-hand experience and close partnerships, we are able to exceed expectations from customers – improving the every-day life for people, today and tomorrow.