



FRONTIER™ 5513&5513R

High-Speed Micro Centrifuges



Compact Micro Centrifuges with Modern Touch-Wheel Interface Ideal for High-Speed Lab Applications

Frontier 5513 and 5513R Benchtop Micro Centrifuges, as high-speed centrifuges, are capable of generating approximately 17000 x g. With refrigeration capabilities (FC5513R), five optional rotors are designed for clinical, industrial, and research applications. Engineered with convenient operation in mind, FC5513 and FC5513R feature a uniquely designed splash-proof front panel with touch-wheel control on an intuitive interface. The compact design saves valuable bench space in the lab.

Unique Features:

- Thanks to rotors compatible with microtubes, and spin columns, the Frontier 5513 and 5513R centrifuges can be applied in molecular biology applications. Additionally, when equipped with the appropriate rotor options, these centrifuges can also be used in diagnostic settings for hematocrit capillaries and PCR tubes/strips.
- Designed for ease of operation, the FC5513 and FC5513R feature convenient control on a protective splash-proof interface, which allows for responsive operation—even when wearing gloves.
- With a small footprint, Frontier 5513 and 5513R centrifuges are compact enough to save valuable space.

FRONTIER™ 5513&5513R High-Speed Micro Centrifuges

Sleekly designed interface enables smooth operation for a great user experience

- Easy-to-Use touch-wheel interface for parameter adjustments
- Convenient interface shows both set and actual parameters
- One-touch toggling between RPM/RCF, Acc/Dec
- Crisp display on a double-line LCD display with light blue backlight

Solid engineering to ensure functionality and reliability

- True splash-proof panel protects the centrifuge from accidental sample spilling
- Maintenance-free induction motor produces maximum G-force of 17317 x g for FC5513 and 17157 x g for FC5513R
- Speeds up to 13500 rpm in less than 15 seconds with 24 x 1.5/2.0 ml rotor
- 10 acceleration/deceleration settings
- 99 memory sets to quickly store and recall commonly used parameters
- FC5513R model has refrigeration capabilities from 40°C to -20°C
 - R290, an environmentally friendly coolant, contributes to the eco-friendliness of refrigerated centrifuges by minimizing their environmental impact and supporting efforts to combat global warming
 - Pre-cool feature in quickly lowers the temperature of rotor and chamber before a run

Flexible rotor selections to cover wide range of laboratory applications

- Works with microtube rotors with different rotor capacity – 18 x 1.5/2.0 ml or 24 x 1.5/2.0 ml
- Compatible with up to 7 rotor option and maximum rotor capacity of 24 x 1.5/2.0 ml
- Support spin-column and hematocrit capillary tubes through additional rotor options

Safety features that prevent injury

- Sealed and TÜV certified rotors to safeguard operators from harmful aerosols
- Rotor imbalance sensing systems stops the unit when it detects an imbalanced load
- Lid-locking system prevents centrifuge from opening during operation (FC5513R)



FRONTIER™ 5513&5513R High-Speed Micro Centrifuges

Specifications

Model	FC5513		FC5513R	
Order No.	230V: 30393187	120V: 30393188	230V: 83042059	120V: 83042060
Speed Range	200 rpm – 13500 rpm; 10 rpm / increments		200 rpm – 14500 rpm; 10 rpm / increments	
Maximum RCF	17317 x g; 10 x g / increments		17157 x g; 10 x g / increments	
Maximum Capacity (Rotor)	Angle Rotor: 24 x 1.5/2.0 ml			
Temperature Range	Air cooled		-20 °C to 40 °C, 1 °C/ increments	
Refrigerant	N/A		R290 (Propane)	
Running Time	Quick Spin, 10 sec to 99 hr 59 min, or continuous			
Noise Level (depending on the rotor)	≤ 60 + 2 dB(A)		≤ 56 + 2 dB(A)	
Acc/Dec Levels	10/10			
Allowable Density at Maximum Speed	1.2 g/ml			
Allowable Kinetic Energy	2129 Nm		2266 Nm	
AC Power	230 V/50 - 60 Hz	120 V/50 - 60 Hz	230 V/50 - 60 Hz	120 V/50 - 60 Hz
Voltage Fluctuation	± 10%			
Current Consumption	1.05 A	1.9 A	1.8 A	1.9 A
Power Consumption	170 W		320 W	
Dimensions (W x D x H)	277 x 351 x 231 mm / 10.9 x 13.8 x 9.1 in		280 x 555 x 287 mm / 11.0 x 21.9 x 11.3 in	
Net Weight (without rotor)	14 kg / 30.9 lb		33 kg / 73 lb	
Shipping Dimensions (W x D x H)	370 x 460 x 360 mm / 14.6 x 18.1 x 14.2 in		390 x 690 x 390 mm / 15.4 x 27.2 x 15.4 in	
Shipping Weight (without rotor)	14 kg / 30.9 lb		38 kg / 83.5 lb	
Ambient conditions (EN/IEC 61010-1)	Environment	For indoor use only		
	Altitude	Use up to an altitude of 2000 m		
	Ambient temperature	5 °C up to 35 °C		
	Max. relative humidity	Max. relative humidity 80 % for temperatures up to 31°C, Decreasing linearly to 50 % relative humidity up to 35°C.		
EMC	EN/IEC 61326-1 Class B emissions, Basic immunity FCC Class B emissions			
Not suitable for use in hazardous environments.				

Accessories

	Order No.	30472302			
	Description	Rotor Angle 24 x 1.5/2.0 ml BIOSEALS V1			
	Compatible with	FC5513		FC5513R	
	Max. Speed	13500 rpm		13000 rpm	
	Max. RCF	17317 x g		16058 x g	
Accessories					
Order No.	Description	Vol./Tube	Diameter	Tube Type	No. of Tubes/Rotor
Without Adapter	Rotor Angle 24 x 1.5/2.0 ml BIOSEALS V1	1.5/2.0 ml	11 mm	Microtube	24
30130885	Adapter 1 x 0.5 ml D8 mm, 6 pk	0.5 ml	8 mm	Microtube	24
30130884	Adapter 1 x 0.2/0.4 ml D6 mm, 6 pk	0.2/0.4 ml	6 mm	Microtube	24

FRONTIER™ 5513&5513R High-Speed Micro Centrifuges

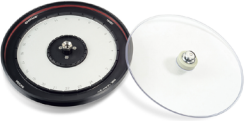
	Order No.	30472304			
	Description	Rotor Hematocrit 24 x Capillaries V1			
	Compatible with	FC5513	FC5513R		
	Max. Speed	13000 rpm	-		
	Max. RCF	16058 x g	-		

Accessories

Order No.	Description	Vol./Tube	Diameter	Tube Type	No. of Tubes/Rotor
Without Adapter	Rotor Hematocrit 24 x Capillaries V1	-	1.9 mm	Capillaries	24

	Order No.	30210898			
	Description	Rotor Angle 24 x 2.0 ml Spin Column			
	Compatible with	FC5513	FC5513R		
	Max. Speed	13500 rpm	-		
	Max. RCF	17317 x g	-		

Accessories

Order No.	Description	Vol./Tube	Diameter	Tube Type	No. of Tubes/Rotor
Without Adapter	Rotor Angle 24 x 2.0 ml Spin Column	2 ml	11 mm	Spin Column	24

	Order No.	83041006			
	Description	Rotor Angle 18 x 1.5/2.0 ml			
	Compatible with	FC5513	FC5513R		
	Max. Speed	-	14500 rpm		
	Max. RCF	-	17157 x g		

Accessories

Order No.	Description	Vol./Tube	Diameter	Tube Type	No. of Tubes/Rotor
Without Adapter	Rotor Angle 18 x 1.5/2.0 ml	1.5/2.0 ml	11 mm	Microtube	18
30130885	Adapter 1 x 0.5 ml D8 mm, 6 pk	0.5 ml	8 mm	Microtube	18
30130884	Adapter 1 x 0.2/0.4 ml D6 mm, 6 pk	0.2/0.4 ml	6 mm	Microtube	18

	Order No.	83041014			
	Description	Rotor Angle 4 x 8-Place PCR Strip V1			
	Compatible with	FC5513	FC5513R		
	Max. Speed	13500 rpm	13000 rpm		
	Max. RCF	14669 x g	13602 x g		

Accessories

Order No.	Description	Vol./Tube	Diameter	Tube Type	No. of Tubes/Rotor
Without Adapter	Rotor Angle 4 x 8-Place PCR Strip V1	0.2 ml	6	8-w PCR Strip	32

Shortcut list:

ID – auto rotor identification
FA – Conical bottom / Falcon®

Hi – version with higher speed
FB – Flat bottom

Vac – Vacutainer®
RB – Round bottom

Sar – Sarstedt
Rim – Skirted conical bottom

FRONTIER™ 5513&5513R High-Speed Micro Centrifuges

Other Standard Features and Equipment

Microprocessor control, Imbalance switch-off, Audible signal at the end of each run with melody options, Emergency release, 99 memory sets, Ten acceleration and ten deceleration rates, Pre-selection of running time from 10 sec to 99 hr 59 min or continuous, Quick spin for short runs.

Compliance

See Declaration of Conformity available CE Declarations | OHAUS

Outline Dimensions

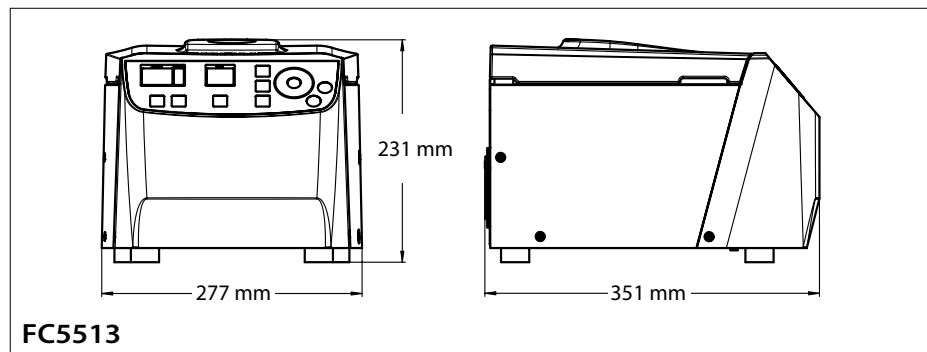
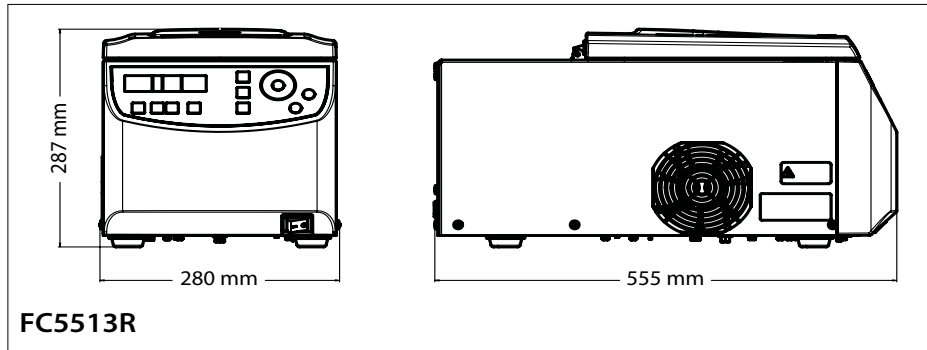

Click or scan
for the web



80775535_D 20250829 © Copyright OHAUS Corporation

OHAUS CORPORATION

Tel: 800.672.7722
973.377.9000
Fax: 973.944.7177

www.ohaus.com

*The management system
governing the manufacture
of this product is
ISO 9001:2015 certified.*

