

LHTV-12-HG

Product Description

These Ultra Touch refrigerators offer precise temperature control and advanced digital monitoring, ideal for clinical and research settings. They feature variable speed compressor technology for exceptional performance and energy efficiency. Experience an intuitive color touchscreen controller, offering multi-layered access and data logging capabilities. Protect your samples with forced draft air circulation using patented air flow technology and customizable alarms with remote contacts. Also enjoy the benefit of natural, hydrocarbon refrigerants for energy savings and a greener laboratory footprint. This refrigerator is constructed with durable powder-coated steel, a self-closing glass door, a keyed access lock, LED interior lighting, and adjustable interior shelving. Also included is a comprehensive 3-year parts and labor warranty with a generous 7-year compressor warranty to protect your investment. With these refrigerators, you'll increase performance and maximize efficiency in your lab.

Images



Certifications



General Description and Application

| | |
|----------------------------------|--|
| Storage capacity (cu. ft) | 12 Cu. Ft. |
| Door | One (1) swing glass door, self-closing, right hinged, not reversible, magnetic door gasket |
| Shelves | Three (3) adjustable shelves (adjustable in 1/8" increments) |
| Mounting and Installation | Swivel casters - locking front casters |
| Interior lighting | LED interior lights are safety shielded and switch controlled |
| Airflow Management | Forced draft air circulation, patented air flow technology |
| External probe access | 3/4" probe access port on rear wall |
| Insulation | Cabinet is foamed-in-place with EPA compliant high-density urethane foam |
| Exterior materials | White powder coated steel |
| Access control | Keyed door lock; compatible with optional digital lock (Pyxis, Omnicell, and AcuDose RX) |
| General warranty | Three (3) year parts and labor warranty |
| Compressor warranty | Seven (7) year compressor warranty |
| Product Weight (lbs) | 223 |
| Shipping Weight (lbs) | 256 |
| Rated Amperage | 2 Amps |
| Power Plug/Power Cord | NEMA 5-15 plug |
| Facility Electrical Requirement | 110 - 120V AC, 15A breaker, NEMA 5-15 receptacle |
| Agency Listing and Certification | ETL, C-ETL listed. Meets or exceeds ENERGY STAR® v2.0 for Laboratory Refrigerators. Official listing pending - see energystar.gov |

Performance

| | |
|---|---|
| Maximum temperature variation (Cabinet air) | +/- 1° C |
| Stability (Simulator ballast) | +/- 0.2° C |
| Adjustable Temperature Range | 2° C to 15° C |
| Stability (Simulator bag) | Non-applicable |
| Energy Consumption (KWh/day) | 1.2 KWh/day *meets ENERGY STAR® v2.0 for Laboratory Refrigerators |
| Average Heat Rejection (BTU/hr) | 330 BTU/h |
| Noise Pressure Level (dBA) | 40 dBA or less installed |
| Pull down time to nominal operating temp | < 30 min (empty) |

Performance Note

Max temperature variation based on an empty chamber at steady state using 15 bare (unweighted) thermocouple probes. Product loading, door openings, and ambient conditions will affect performance. Stability of simulator ballast based on bottle probe provided with the unit located center of empty chamber at steady state, no door openings

| Refrigeration System | |
|----------------------|--|
| Compressor | Hermetic, variable speed |
| Refrigerant | EPA SNAP compliant R600a Isobutane (Hydrocarbon natural refrigerant) |
| Condenser | Tube and grid, high efficiency fan forced air |
| Evaporator | Fin and tube, high efficiency fan forced air |
| Defrost | Cycle Defrost |

| Controller, Configuration, Alarms and Monitoring | |
|--|--|
| Controller technology | Microprocessor with color touchscreen (8in) input and display, C°/F° switchable, resolution is 0.1° C/0.2° F |
| Battery Backup | High capacity 12V battery for controller temperature and alarm display and logging only, no cooling active |
| Display technology | 8" touchscreen featuring: Security and Access: Multi-level password protection: User, Supervisor, and Admin roles for access and control. advanced controls: customizable passwords/PINs: Ensures tailored access for your team. calibration adjustments: fine-tune temperature offsets for precise measurements. visual and user interface: intuitive touch screen: pinch-to-zoom, scrollable graphs, and customizable display options. Adjustable display settings: screen brightness, real-time temperature comparison to alarm points. |
| Digital Communication | 4-20mA Output |
| Data Transfer | Non-applicable |
| External alarm connection | Remote alarm contacts |

| | |
|--------|---|
| Alarms | Audible & Visual Alarms: customizable sounds and volumes; silent mode with visual persistence. Alarm delays: adjustable settings for door, temperature, and power loss alarms to prevent nuisance alerts. Ring-back functionality. Audible alarms re-engage after a preset delay if the condition persists. |
|--------|---|

| | |
|---------------|--|
| Display Probe | Product simulator bottle with glass bead media |
|---------------|--|

Disclaimers
 Refrigerator requires a minimum 2" of clearance around back and sides of the unit for proper ventilation (more if next to heat rejecting equipment) - improper installation will void the warranty and will lead to temperature maintenance issues, overheating and possible failure

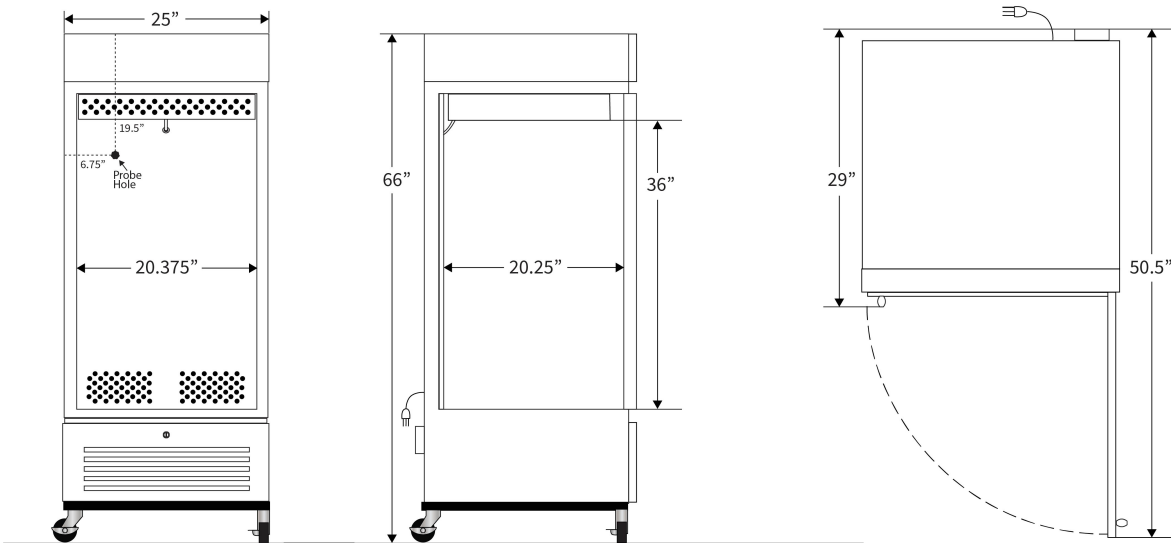

| Contact | | |
|------------------|--------------|--|
| Customer Service | 800-521-0754 | sales@labrepco.com |

Rev_03032025