



Please read user's manual before
operating equipment

Original Instructions

LABCONCO CORPORATION

8811 Prospect Avenue
Kansas City, MO 64132
(800) 821-5525 | +1 (816) 333-8811
labconco.com

User's Manual

CentriVap® Cold Traps



Register this product

Centrivap® Cold Traps

2024—Present

8601xxx

8611xxx

8621xxx

Copyright © 2024 Labconco Corporation. The information contained in this manual and the accompanying products are copyrighted and all rights reserved by Labconco Corporation. Labconco Corporation reserves the right to make periodic design changes without obligation to notify any person or entity of such change.

Warranty

Labconco Corporation provides a warranty to the original buyer for the repair or replacement of parts and reasonable labor as a result of normal and proper use of the equipment with compatible chemicals. Broken glassware and maintenance items, such as filters, gaskets, light bulbs, finishes, and lubrication are not warranted. Excluded from warranty are products with improper installation, erratic electrical or utility supply, unauthorized repair, use with incompatible chemicals, or non-factory modifications to the original product.

The warranty for CentriVap® Cold Traps will expire one year from date of installation or two years from date of shipment from Labconco, whichever is sooner. Warranty is non-transferable and only applies to the owner (organization) of record.

Buyer is exclusively responsible for the set-up, installation, verification, decontamination, or calibration of equipment. This limited warranty covers parts and labor, but not transportation and insurance charges. If the failure is determined to be covered under this warranty, the dealer or Labconco Corporation will authorize repair or replacement of all defective parts to restore the unit to operation. Repairs may be completed by 3rd party service agents approved by Labconco Corporation. Labconco Corporation reserves the rights to limit this warranty based on a service agent's travel, working hours, the site's entry restrictions and unobstructed access to serviceable components of the product.

Under no circumstances shall Labconco Corporation be liable for indirect, consequential, or special damages of any kind. This warranty is exclusive and in lieu of all other warranties whether oral, or implied.

Returned or Damaged Goods

Do not return goods without the prior authorization from Labconco. Unauthorized returns will not be accepted. If your shipment was damaged in transit, you must file a claim directly with the freight carrier. Labconco Corporation and its dealers are not responsible for shipping damages.

The United States Interstate Commerce Commission rules require that claims be filed with the delivery carrier within **fifteen (15) days** of delivery.

Limitation of Liability

The disposal and/or emission of substances used in connection with this equipment may be governed by various federal, state, or local regulations. All users of this equipment are required to become familiar with any regulations that apply in the user's area concerning the dumping of waste materials in or upon water, land, or air and to comply with such regulations. Labconco Corporation is held harmless with respect to user's compliance with such regulations.

For additional questions or support:

Labconco Customer Care +1 (816) 333-8811

Labconco Technical Support (800) 821-5525

Hours 7:30 a.m.-5:30 p.m. CST

**Part # 8606500 Rev. -
ECO P426**

Table of Contents

1: INTRODUCTION	6
About This Manual	6
Contents Included	6
2: BEFORE YOU INSTALL	7
Location Requirements	7
Space Requirements	7
Clearance Requirements	7
Electrical Requirements	8
Exhaust Requirements	8
Vacuum Pump Requirements	8
Chemical Traps	9
3: SAFETY PRECAUTIONS	10
Typographical Conventions	10
General Safety Precautions	12
Safety Precautions for this Product	14
For Hydrocarbon Refrigeration only	14
Solvent Safety Precautions	14
Replacement components and servicing	15
4: INSTALLATION	16
Unpacking	16
Installation	18

Electrical Connection	19
Ground Wire	19
5: USING YOUR COLD TRAP	20
Feature Overview	20
Chemical Resistance of Cold Trap Components	21
Start-up	21
Shutdown	22
6: MAINTAINING YOUR COLD TRAP	23
Maintenance Safety Precautions	23
Recommended Maintenance Schedule	24
7: ACCESSORIES	26
Installing a Secondary Chemical Trap	26
Installing a Glass Trap	27
8: TROUBLESHOOTING	28
APPENDIX A: PARTS LIST	30
APPENDIX B: DIMENSIONS	33
APPENDIX C: SPECIFICATIONS	36
Power Data	36
Environmental Conditions	36

1: Introduction

Congratulations on the purchase of a Labconco Cold Trap. The Cold Trap is designed to protect the vacuum pump by trapping moisture, vapors, and corrosive fumes as they evaporate from the samples. The stainless-steel trap is used for aqueous and organic applications. For corrosive applications, the optional Glass Trap insert should be used. This equipment is the result of years of experience in manufacturing laboratory equipment, and users like you suggested many of its features to us.

Please acquaint yourself with this manual and keep it handy for future reference.

About This Manual



This manual is written for the installer and user of this product. This manual contains important operation and safety information. When you see a symbol, such as the INFO symbol to the left, pay close attention to the information provided. Before installing or operating this product, you must read Section 3: Safety Precautions.

Contents Included

The following items are packaged with the product.

- User's manual thumb drive
- Ground Wire Assembly
- Tubing – Clear PVC
- (2) Hose Clamps
- Power Cord

2: Before You Install

Before you install the product, the site should be planned for installation. Examine the location where you intend to install it. You must be certain that the area is level and of solid construction. In addition, a means to exhaust the vacuum pump must be provided and a dedicated source of electrical power must be located near the installation site.

Location Requirements

The Cold Trap should be located on a surface that is stable, flat, and level. The performance of the Cold Trap refrigeration system can be adversely affected by high ambient room temperature. For optimal performance, the ambient room temperature should be 70 – 75°F (21 – 24°C).

Space Requirements

See Appendix B: Dimensions for overall product dimensions.

Clearance Requirements

A minimum clearance of at least three inches (7.6 cm) should be allowed between the sides and back of the Cold Trap and adjacent wall surfaces or other equipment. Restriction of the airflow through the cabinet during operation could adversely affect performance.

Electrical Requirements

The product models have the following electrical requirements.

Catalog Number	Typical Operating Current (Amps)	Electrical Circuit Requirements*	
8601000, 8601100	5.9 A	115V, 60 Hz, 7A	1 Phase
8601030, -40, -50, -70, -80, -90 8601130, -40, -50, -70, -80, -90	2.6 A	230V, 50 Hz, 3A	1 Phase
8601010, -15 8601110, -15	2.9 A	230V, 60 Hz, 3A	1 Phase
8611100	11.2 A	115V, 60 Hz, 12A	1 Phase
8611130, -40, -50, -70, -80, -90	5.2 A	230V, 50 Hz, 6A	1 Phase
8611110, -15	5.6 A	230V, 60 Hz, 6A	1 Phase
8621100	13 A	115V, 60 Hz, 13A	1 Phase
8621130, -40, -50, -70, -80, -90	6.3 A	230V, 50 Hz, 7A	1 Phase
8621110, -15	6.5 A	230V, 60 Hz, 7A	1 Phase

*Electrical Requirements, 'V' = VAC (Voltage with alternating current), 'A' = Amperes

A dedicated outlet with an appropriate circuit breaker should be located as close as possible to the product. Consult your local electrical codes for properly rated circuit breakers. For safe operation, the dedicated outlet must provide a protective earthing ground connection to the product.

Exhaust Requirements



Solvents used in the Cold Trap can cause skin, eye, respiratory and digestive system disorders. The Cold Trap should be located within a fume hood if hazardous or flammable solvents are used. Heating of materials could lead to the liberation of hazardous gases. In all cases, regardless of the solvent used, it is strongly recommended that the vacuum pump is vented into a fume hood. An accessory secondary trap is available to minimize the exhausting of solvents into the atmosphere. This does not, however, negate the need to exhaust the vacuum pump into a fume hood. Failure to properly vent the system will expose personnel to potentially harmful chemicals.

The Cold Trap has not been evaluated by an approval agency for the use of biological, radio toxins or flammable liquids or materials.

Vacuum Pump Requirements

The inlet fitting on the vacuum pump must be suitable for 0.50 ID hose.



When selecting the vacuum pump, it is very important to consider the flammability of the solvent that will be used. If the solvents are flammable, an explosion-proof vacuum pump or one suitable for the solvents to be processed is recommended. To ensure that aggressive vapors do not damage the vacuum pump, it is recommended that all internal

wetted parts of the vacuum pump are PTFE or PTFE coated when using aggressive solutions.

Chemical Traps

The Cold Trap will not provide complete vacuum pump protection under all circumstances. Variables that influence the Cold Traps trapping ability are volatility of the solvents, solvent volumes, solvent temperatures, and vacuum levels. Some scenarios may require a Chemical Trap for additional vacuum pump protection. This in-line canister is placed after the Cold Trap and before the vacuum pump and holds inserts for specific sample types. Acid, solvent, moisture, and radioisotope inserts are available.



Several components within the CentriVap Cold Trap are made from stainless steel or other materials and can be degraded if exposed to acids. Contact Labconco before evaporating acids.

3: Safety Precautions

Before unpacking, installing, operating, maintaining, or servicing this equipment, read the following safety warnings and precautions.

Avant le déballage, l'installation, le fonctionnement, l'entretien ou la maintenance de cet équipement, lire les avertissements de sécurité et les précautions d'emploi.



CAUTION – See Manual. When this symbol is on the equipment, it indicates a caution that is detailed in this manual.

MISE EN GARDE – Voir le manuel. Lorsque ce symbole est apposé sur l'équipement, il renvoie à une mise en garde détaillée dans ce manuel.

Typographical Conventions



DANGER – An imminently hazardous situation which, if not avoided, will result in death or serious injury.

DANGER – Situation dangereuse imminente qui, si elle n'est pas évitée, peut entraîner la mort ou des blessures graves.



CAUTION – Indicates a potentially hazardous situation which, if not avoided, may result in minor or moderate injury or damage to property.

MISE EN GARDE – Signale une situation potentiellement dangereuse qui, si elle n'est pas évitée, peut provoquer des blessures mineures à modérées ou des dommages matériels.



NOTE – Advice or suggestions to help the process.

REMARQUE – Conseils ou suggestions pour le déroulement du processus.



BURN RISK (HIGH TEMPERATURE) – Air or components that will be very hot. Take care not to touch these defined areas. Failure to avoid these areas may result in moderate to severe injury.

RISQUE DE BRÛLURE (TEMPÉRATURE ÉLEVÉE) – Air ambiant ou composant devenant très chaud. Veiller à ne pas toucher ces zones délimitées. L'absence de précaution pour éviter ces zones peut entraîner des blessures modérées, voire graves.



EXTREME COLD (LOW TEMPERATURE) – Air or components that will be very COLD. Take care not to touch these defined areas. Failure to avoid these areas may result in moderate to severe injury.

FROID INTENSE (TEMPÉRATURE BASSE) – Air ambiant ou composant devenant très froid. Veiller à ne pas toucher ces zones délimitées. L'absence de précaution pour éviter ces zones peut entraîner des blessures modérées voire graves.



PINCH POINT – Areas or components that can pinch or cut. Take care not to touch these defined areas.

POINT DE PINCEMENT – Zones ou composants présentant un risque de pincement ou de coupure. Veiller à ne pas toucher ces zones délimitées.



MOVING PARTS – Areas or components that contain moving parts. Take care not to touch these defined areas.

PIÈCES MOBILES – Zones ou composants contenant des pièces mobiles. Veiller à ne pas toucher ces zones délimitées.



RISK OF ELECTRICAL SHOCK – The specified procedure or area poses a risk of electrical shock. ALWAYS disconnect main power cord or electrical supply before proceeding.

RISQUE DE CHOC ÉLECTRIQUE – La procédure ou la zone spécifiée présente un risque de choc électrique. TOUJOURS débrancher le cordon d'alimentation secteur ou l'alimentation électrique avant toute intervention.



FLAMMABLE / NO SOLVENTS – Do not place flammable liquids or solvents in this product.

INFLAMMABLE / PAS DE SOLVANTS – Ne placez aucun liquid inflammable dans cette produit.



LIFTING HAZARD – Do not lift or move this equipment without assistance.
DANGER DE LEVAGE – Ne pas soulever ou déplacer cet équipement sans assistance.



MAGNETIC FIELD IN USE – Magnets or magnetic field present.
CHAMP MAGNETIQUE UTILISE – Présence d'aimants ou de champ magnétique.



DO NOT TOUCH – Components or areas indicated are sensitive and will suffer damage if touched. Take care not to touch these defined components or areas. Failure to avoid these areas will result in damage to the product.
NE PAS TOUCHER – Les composants ou les zones indiquées sont sensibles et subiront des dégâts s'ils sont touchés. Veiller à ne pas toucher ces composants ou zones délimité(e)s. L'absence de précaution pour éviter ces zones endommagera le produit.



TOOL REQUIRED – Tool required to access specified area.
OUTIL NÉCESSAIRE – Outil nécessaire pour accéder à la zone spécifiée.

General Safety Precautions

Follow all the safety precautions described in this section.



Before removing any panels which require a tool for removal, ALWAYS disconnect the main power cord or electrical supply. Failure to remove all electrical power before proceeding will result in moderate to serious injury, death, or damage to property.

Avant le retrait d'un panneau nécessitant l'utilisation d'un outil, TOUJOURS débrancher le cordon d'alimentation secteur ou l'alimentation électrique. Le non-respect de la consigne consistant à couper complètement l'alimentation électrique avant toute intervention peut entraîner des blessures graves, la mort ou des dommages matériels.



Never contact moving parts with your person. Failure to avoid moving parts will result in moderate to serious injury, death, or damage to property.

Ne jamais toucher les parties mobiles. Le non-respect de la consigne consistant à éviter les pièces mobiles peut entraîner des blessures graves, la mort ou des dommages matériels.



Never misuse this product. Never disable, override, or otherwise bypass safety guards, panels, switches, sensors or alarms. Doing so will result in moderate to serious injury, death, or damage to this product or property.

Ne jamais utiliser ce produit à mauvais escient. Ne jamais désactiver, annuler ou contourner les capots, panneaux, interrupteurs, capteurs ou alarmes de sécurité. Ceci entraînerait des blessures graves, la mort ou des dommages matériels à ce produit ou à d'autres biens.



If the unit is not operated as specified in this manual it may impair the protection provided by the unit.

Si l'unité n'est pas utilisée comme spécifié dans ce manuel il peut diminuer la protection fournie par l'unité.



Do not position the unit so that it is difficult to operate the main disconnect device.

Ne placez pas l'appareil de sorte qu'il est difficile de faire fonctionner le dispositif principal de déconnexion.



Do not lift or move this equipment without assistance.

Ne pas soulever ou déplacer cet équipement sans assistance.

Safety Precautions for this Product



Do not use any detachable power cord that is not adequately rated for the unit.
Ne pas utiliser un fil électrique amovible qui n'est pas du tension nominale de l'appareil.

For Hydrocarbon Refrigeration only



- **DANGER** – Risk of fire or explosion. Flammable refrigerant used. Do not use mechanical devices to defrost refrigerator. Do not puncture refrigerant tubing.
DANGER – Risque d'incendie ou d'explosion. Réfrigérant inflammable utilisé. N'utilisez pas d'appareils mécaniques pour dégivrer le réfrigérateur. Ne percez pas les tubes de réfrigérant.
- **DANGER** – Risk of fire or explosion. Flammable refrigerant used. To be repaired only by trained service personnel.
DANGER – Risque d'incendie ou d'explosion. Réfrigérant inflammable utilisé. À réparer uniquement par un personnel de service qualifié.
- **WARNING** – Ensure all ventilation openings are not obstructed.
AVERTISSEMENT – Assurez-vous que toutes les ouvertures de ventilation ne sont pas obstruées.
- **CAUTION** – Risk of fire or explosion. Flammable refrigerant used. Consult repair manual/owner's guide before attempting to service this product. All safety precautions must be followed.
ATTENTION – Risque d'incendie ou d'explosion. Réfrigérant inflammable utilisé. Consultez le manuel de réparation/guide du propriétaire avant d'essayer de réparer ce produit. Toutes les précautions de sécurité doivent être respectées.
- **CAUTION** – Risk of fire or explosion. Dispose of properly in accordance with federal or local regulations. Flammable refrigerant used.
ATTENTION – Risque d'incendie ou d'explosion. Éliminer correctement conformément aux réglementations fédérales ou locales. Réfrigérant inflammable utilisé.
- **CAUTION** – Risk of fire or explosion due to puncture of refrigerant tubing. Follow handling instructions carefully. Flammable refrigerant used.
ATTENTION – Risque d'incendie ou d'explosion dû à la perforation du tube de réfrigérant. Suivez attentivement les instructions de manipulation. Réfrigérant inflammable utilisé.

Solvent Safety Precautions



CAUTION: Solvents used in the Cold Trap may be flammable or hazardous. Use extreme caution and keep sources of ignition away from the solvents. When using flammable or hazardous solvents, both the Cold Trap and the vacuum pump should be operated inside a fume hood.

Hazardous materials, such as strong acids or bases, radioactive substances, and volatile organics, must be handled carefully and promptly cleaned up if spilled.

Do not store flammable or hazardous solvents within 12 inches (300 mm) of the CentriVap Cold Trap.



The disposal of substances used in connection with this equipment may be governed by various federal, state, or local regulations. All users of this equipment are urged to become familiar with any regulations that apply in the user's area concerning the dumping of waste materials in or upon water, land, or air and to comply with such regulations.

Replacement components and servicing



Component parts shall be replaced with like components.

Authorized service personnel shall perform servicing to minimize the risk of possible ignition due to incorrect parts or improper service.

4: Installation

With the installation site properly prepared, you are ready to unpack and install the equipment. This section covers how to:

- Unpack and move the equipment
- Install the equipment
- Connect electrical service
- Connect service utilities
- Properly exhaust the equipment

Unpacking



The following tools are required to unpack the equipment:

- Box Knife



The following safety precautions must be followed by all personnel unpacking the equipment.

- Wear safety glasses
- Wear gloves
- No loose fitting clothes
- Wear close-toed shoes
- Follow safe-lifting practices
 - The Cold Trap weighs over 70 lbs. (33 Kg). The carton allows for lifting with a mechanical lift truck or hand truck. If you must lift the Cold Trap manually, use at least two (2) persons and follow safe lifting guidelines.

Step 1

Carefully remove the outer carton and inspect the product for damage that may have occurred in transit. If the product is damaged, take pictures of the product and the outer packaging, and notify the delivery carrier immediately. Retain the entire shipment, including outer packaging, intact for inspection by the carrier.



Note: United States Interstate Commerce Commission rules require that claims be filed with the delivery carrier within fifteen (15) days of delivery.

Do not return goods without the prior authorization of Labconco. Unauthorized returns will not be accepted.

If the product was damaged in transit, you must file a claim directly with the freight carrier. Labconco Corporation and its dealers are not responsible for shipping damages.

Do not discard the carton or packing material for the product until all of the components have been checked, installed and tested.

Step 2

Locate the model of Cold Trap you received in the following table. Verify that the components listed are present. If you did not receive one or more of the components listed for your Cold Trap, contact Labconco Corporation immediately for further instructions.

Cold Traps													
Description			Power Cords						Accessories				
Catalog #	Voltage(V)	Frequency (Hz)	1334500	1338000	1336100	1332700	1332600	1345700	1331800	7828606	1488800	7464600	1089029
			Connector: IEC C13 Plug: NEMA 5-15	Connector: IEC C13 Plug: NEMA 6-15	Connector: IEC C13 Plug: CEE 7/7	Connector: IEC C13 Plug: CH1-10P	Connector: IEC C13 Plug: BS 1363	Connector: IEC C13 Plug: SANS 164-1	Connector: IEC C13 Plug: AU1 10P	Tubing, 1/2 ID x 38"	Hose Clamps (2)	Ground Wire Assembly	User Manual Thumbdrive
86xxx00	115	60	X							X	X	X	X
86xxx10	230	60		X						X	X	X	X
86xxx15	230	50					X			X	X	X	X
86xxx30	230	50			X					X	X	X	X
86xxx40	230	50				X				X	X	X	X
86xxx50	230	50					X			X	X	X	X
86xxx70	230	50						X		X	X	X	X
86xxx80	230	50							X	X	X	X	X
86xxx90	230	50			X	X	X	X	X	X	X	X	X

Installation

The relative position of the Cold Trap and the vacuum pump is critical. The Cold Trap should always be placed before the vacuum pump. Air to cool the refrigeration system of the Cold Trap is drawn into the right side of the Cold Trap cabinet and exhausts out the left side of the cabinet. A minimum of 3" should be allowed between the sides of the Cold Trap and the adjacent wall surfaces. Restriction of the airflow through the cabinet during operation could adversely affect performance.

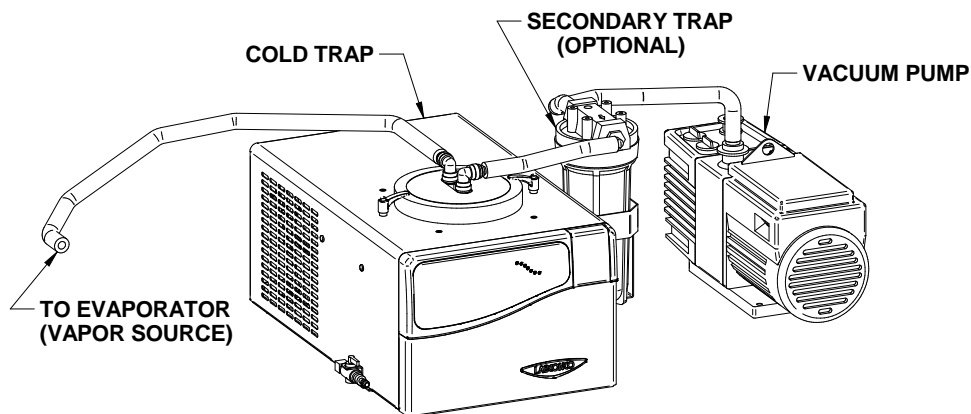

Once positioned properly, the system can be connected with the hoses provided. Attach one end of the hose to the evaporator and the other end of this hose to one of the barb fittings on the Cold Trap Cover Assembly. Secure the hoses with the clamps supplied. Attach another hose to the remaining barb fitting on the Cold Trap Cover and clamp securely. If the accessory Secondary Trap is not used, attach the other end of this hose to the inlet port on the vacuum pump. If the accessory Secondary Trap is used, install the Secondary Trap as explained in *Chapter 7: Accessories*.



WARNING: Solvents used in the Cold Trap can cause skin, eye, respiratory and digestive system disorders. Locate the Cold Trap inside a fume hood. It is recommended that the vacuum pump be located inside a fume hood or other laboratory ventilation device if hazardous solvents are being used. If this is not possible, the vacuum pump should have a hose attached to the exhaust port and the other end of the hose should be positioned inside the fume hood or ventilation device.

Electrical Connection

Plug the power cord into the receptacle on the back of the Cold Trap and plug the other end into a suitable power receptacle. Plug the power cord from the vacuum pump into a suitable receptacle.

Ground Wire



CAUTION: Solvents may be flammable. When draining the CentriVac Cold Trap always attach the other end of the grounding clip to the solvent catch pot to eliminate the risk of electrostatic spark ignition.

Attach one end of the included ground wire to the stainless-steel elbow on the drain tubing on the right or left side (depending on model) of the Cold Trap

5: Using Your Cold Trap

This section details the functional features and proper techniques for safely and efficiently using the Cold Trap.

Feature Overview

Figure 7-1 illustrates key features and components of the product.

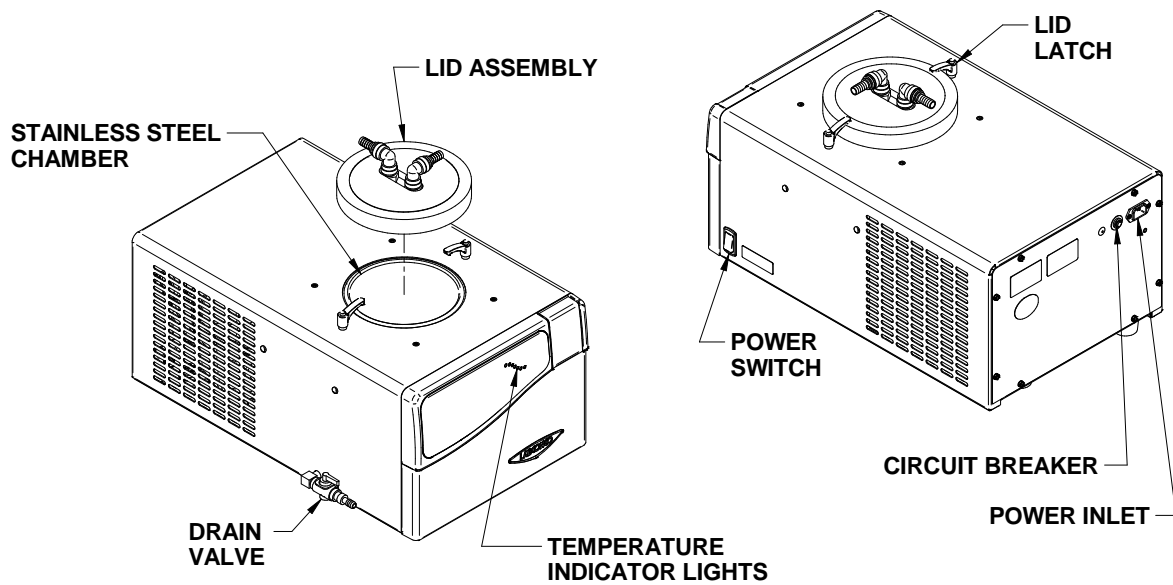

Figure 7-1

Chemical Resistance of Cold Trap Components

The Cold Trap is designed to be chemically resistant. However, by necessity, the Cold Trap is comprised of a number of different materials, some of which may be attacked and degraded by corrosive chemicals. The degree of degradation is obviously dependent on the concentration and duration of exposure. Some major components of the Cold Trap that are susceptible to degradation are as follows:

COMPONENT	MATERIAL	Acids							Bases		Solvents														
		Acetic Acid 20%	Boric Acid	Formic Acid	Hydrobromic Acid 20%	Hydrochloric Acid 20%	Nitric Acid 20%	Sulfuric Acid 10%	Trifluoroacetic Acid (TFA)	Ammonium Hydroxide		Acetone	Acetonitrile	Chloroform	Dimethyl Formamide	Dimethyl Sulfoxide (DMSO)	Ethanol	Ethyl Acetate	Hexanes	Isopropanol	Methanol	Methylene Chloride	Methyl t-Butyl Ether (MTBE)	Toluene	Water
Cold Trap -50°C																									
Chamber	Stainless Steel				D	D		D																	
Lid	Acrylic							C	D	C		D	D		D	D	C	D		D	C	D		D	D
Cold Trap Gasket	Neoprene		D		D	C	D		D			C	D	D	D		D					D	C	D	D
Cold Trap -84°C & -105°C																									
Chamber	Stainless Steel				D	D		D																	
Lid	Stainless Steel				D	D		D																	
Cold Trap Gasket	Neoprene		D		D	C	D		D			C	D	D	D		D					D	C	D	D
C- Moderate Degradation- Questionable use D- Severe Degradation- Infrequent use recommended- immediate thorough cleaning required																									

If a rotary vane vacuum pump is used, frequent oil changes are required. Many compounds will degrade the oil if allowed to enter to pump.

Diaphragm vacuum pumps sold by Labconco have wetted parts either made from PTFE or protected by PTFE coatings and are suitable for nearly all procedures.

When using compounds in the CentriVap Cold Trap that are hostile to the materials of construction, it is imperative that the equipment is appropriately maintained. After each run, clean up all residues, spills and materials that might have splashed in the chamber.

If the stainless-steel cold trap chamber is attacked by the compounds in use, consider using the optional Glass Trap insert (see Chapter 7: Accessories).

Start-up

- Ensure all hoses are properly attached from Cold Trap to Evaporator and Vacuum Pump.
- Secure the Lid Assembly with the two lid latches.
- Turn power switch ON. The top amber indicator will illuminate. Additional indicators will illuminate, as the Cold Trap gets colder. A green indicator will illuminate when the Cold Trap reaches operating temperature.

Shutdown

- Turn power switch OFF.
- Allow ice to melt until it is free from the walls of the Cold Trap. DO NOT chip ice off the Cold Trap walls as damage may occur.
- Drain the Cold Trap immediately after the collected ice is melted to prevent corrosive liquids from residing in the trap. Flush out the trap with water after draining.
- DO NOT start a rotary vane vacuum pump when the Cold Trap contains any liquid or if liquid is present in the vacuum tubing. The liquid will be drawn into the pump and will contaminate the vacuum pump oil.
- When using a rotary vane vacuum pump the oil in the pump should be checked often. It must be changed if it is cloudy, shows particles or is discolored. The useful life of vacuum pump oil can be extended if the vacuum pump is operated for an extended period with the gas ballast open after the run is over. This allows contaminants to be purged from the hot oil. This must be done with the inlet to the pump blocked off to prevent air from free flowing through the pump. If the pump is operated at an elevated vacuum level, oil will be expelled from the pump and damage will occur.
- If optional secondary traps are used, monitor their condition often and replace them when they are saturated (see Chapter 7: Installing a Secondary Chemical Trap).

6: Maintaining Your Cold Trap

This section details the maintenance required for optimal operation of the Cold Trap.

Maintenance Safety Precautions



The following tools and supplies are required to maintain the equipment:

- Mild non-abrasive cleaning solution
- Soft cloth



The following safety precautions must be followed by all personnel maintaining the equipment.

- Wear safety glasses, and/or additional eye and face protection as required by your Health & Safety Department.
- Wear gloves, and/or additional skin protection as required by safety instructions for cleaning/disinfecting chemicals used. Consult your Health & Safety Department for additional skin protection requirements.
- No loose fitting clothes
- Wear close-toed shoes
- When removing any panels that expose moving or electrical parts, you must follow these instructions before doing so:
 - Disconnect main power cord or electrical service connection.
 - Never touch moving parts such as fan blades or blower wheels.



Recommended Maintenance Schedule

Activity	Maintenance Frequency		
	After each run	Monthly	Annually
Completely empty the trap before the next run.	•		
Clean up all spills. Clean or decontaminate all surfaces using agents suitable for the substance spilled.	•		
Clean lid and gasket using soft cloth and mild, non-abrasive cleaner.	•		
Check oil level of the vacuum pump, if applicable. It should be between MIN and MAX.	•		
If oil shows cloudiness, particles, or discoloration, drain the pump, and replace with fresh oil.	•		
Utilization of acids requires immediate cleaning and neutralization after a run or physical damage to the collection chamber will result.	•		
For Glass Trap Option: If water or ice can be seen in the ethanol (in stainless steel trap), then drain and replace with new ethanol.	•		
For Secondary Trap Option: If media in cartridge has changed color, discard and replace with new insert. For radiochemical trap inserts, no indicator exists; therefore, it should be discarded after each use. In radioactive applications, the system should be monitored with a Geiger counter.	•		
Check the continuity of the protective earth ground between the ground terminal on the power inlet and a bare metal housing panel. Contact Labconco if there is no continuity.		•	

Activity	Maintenance Frequency		
	After each run	Monthly	Annually
Check all hoses & gaskets and replace any that show signs of hardening, permanent set, or deterioration.		•	
Clean exterior surfaces with cloth & non-abrasive cleaner (solvents may damage the finish)		•	
Using a vacuum cleaner with brush attachment, clean the condenser to ensure proper airflow for peak performance.			•

7: Accessories

This section details the available field-installable accessories and approved modifications for your Cold Trap.

Installing a Secondary Chemical Trap

An accessory secondary chemical trap is available to protect the vacuum pump and minimize the exhausting of solvents into the atmosphere. It may be attached to either side of the Cold Trap. After selecting the side, remove the two small plastic hole plugs. Attach the bracket to the side of the Cold Trap housing using the screws provided. Attach the hose from the Cold Trap Lid Assembly to the “out” connector of the canister housing. Connect another hose from the remaining fitting on the Secondary Trap to the inlet port on the vacuum pump. Clamp hoses securely. Unscrew the clear bowl of the canister housing from the head. Remove both the upper and lower caps from the filter cartridge and insert the small end of the cartridge into the hole in the center of the head. Reinstall the clear bowl.

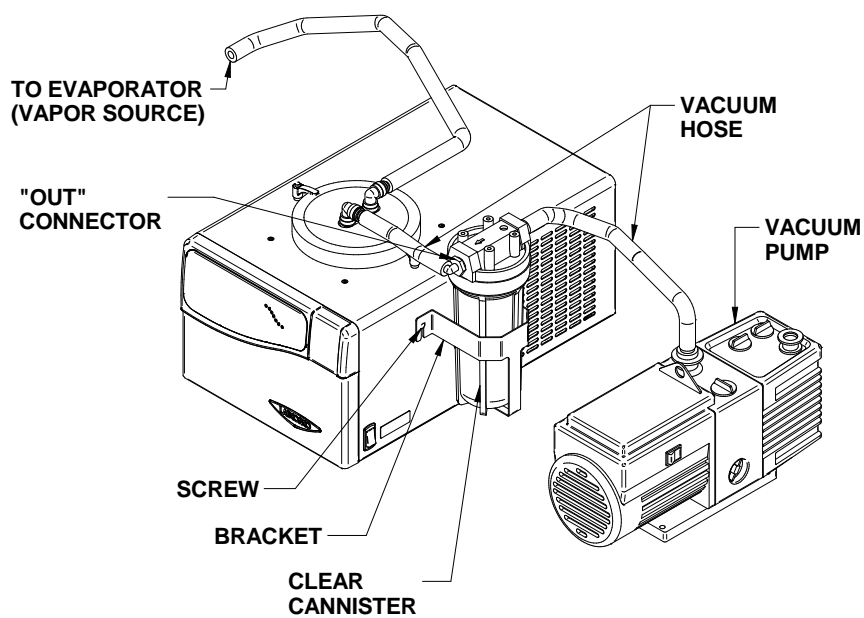

Be sure to use the proper cartridge for your application. Monitor their condition often and replace them when they are saturated. A new acid trap is off-white and changes color to purple when used up. A new moisture trap is blue and changes color to pink when used up. The solvent trap molecular sieve does not change color when saturated so extra care must be taken to determine when a replacement cartridge should be installed. For the radiochemical trap insert, no color indicator exists therefore it should be discarded after each use. Use a Geiger counter to monitor the pump exhaust.



NOTE: The radiochemical cartridge does not meet NRC filter design recommendations. applicable codes. Labconco is not responsible for improper disposal of any materials.

Installing a Glass Trap

An accessory Glass Trap is available for use in the Cold Trap when using corrosive chemicals that could attack the stainless-steel chamber. Lift and rotate the two lid latches. Disconnect the hoses and remove the Cold Trap Lid Assembly. Attach the hose from the Concentrator to the fitting on the center tube of the Glass Trap and clamp securely. Attach the hose from the vacuum pump or Secondary Trap to the other fitting on the Glass Trap and clamp securely. Be certain that the drain valve is closed. Add approximately 500 ml of ethyl alcohol to the stainless-steel trap or enough to ensure the Glass Trap is at least two-thirds immersed. Place the Glass Trap inside the stainless-steel trap, lift and rotate the two latches to hold the Glass Trap in place.



NOTE: After a run, if the ice in the glass trap has melted, the trap must be emptied before the cold trap is started again to prevent it from breaking.

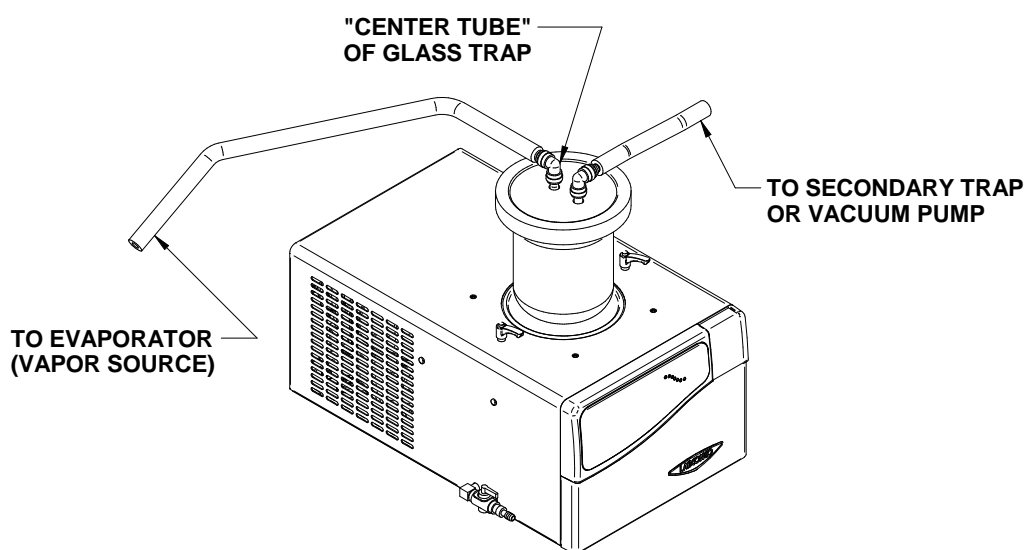

8: Troubleshooting

This section details common troubleshooting for your Cold Trap.

PROBLEM	CAUSE	CORRECTIVE ACTION
Unit will not operate	Unit not connected to electrical power	Connect unit to proper electrical receptacle.
	Circuit breaker blown	Correct electrical problem and reset circuit breaker by pressing button.
Sample odor in lab	Vent hose exhausting into lab area	Redirect hose to fume hood.
Evaporation rate is reduced	Vacuum pump failure	Check pump.
	Obstruction in hose	Remove obstruction or replace hose.
	Lack of adequate vacuum	See below.
No vacuum/poor vacuum	Pump not on	Turn on pump.
	Leaks in lines or connectors or gasket	Locate and repair.
	Foreign material on lid gasket	Clean gasket and lid.
No vacuum/poor vacuum (cont.)	Pump is not functioning properly	Check pump by locating vacuum gauge closer to pump and close off rest of system. Check pump oil for cloudiness or particles and change.

PROBLEM	CAUSE	CORRECTIVE ACTION
Recovery of condensate in Cold Trap is less than normally expected	Cold Trap lid not seated	Hold lid down until vacuum is initiated.
	Ice formed on Cold Trap lid sealing surface	Defrost and wipe dry.
	Secondary Trap Canister not fitted properly	Tighten all connections to and from the Secondary Trap Canister.
	Secondary Trap Insert is spent	Replace with new insert.
	New Secondary Trap has moisture in it	Run vacuum pump for 24 hours to remove moisture.
	Cold Trap is not ON	Check to make sure switch is ON and condensing unit fan is moving air out of the rear of the cabinet.
Frequent oil change needed in pump	Cold Trap does not cool down	Turn vacuum pump OFF and allow Cold Trap to cool for at least 30 min. to reach temperature. -50°C temperature can be checked with a solvent thermometer or digital thermometer.
	Secondary Trap insert is spent	Change insert often.
	Cold Trap is not emptied after each run and dried	Empty the traps (glass or stainless steel) after each run and replace.
	Vacuum too strong for chemical	Use a Secondary Trap insert and diaphragm pump.

Appendix A: Parts List

Cold Trap -50 Models

Table A-1

Item	Quantity Required	Catalog Number	Description
1	1	7394400	Circuit Board
2	1	1307400	Switch
3	1	1327208	Circuit Breaker (115V)
3A	2	1327204	Circuit Breaker (230V)
4	1	1360500	Valve
5	1	7464600	Ground Wire Assembly
6	1	7399700	Lid Assembly Acrylic (Complete)
6A	1	7386701	Lid Assembly Stainless Steel (Complete)
7	2	1559100	Stem Adapter
8	2	1554900	Elbow
9	2	1554700	Stem
10	1	7397605	Glass Trap Assembly (Complete) Optional
11	1	7397606	Glass Trap Lid Assembly
12	1	7871500	Glass Trap
13	1	7515300	Temperature Sensor (not shown)

Figure A-1

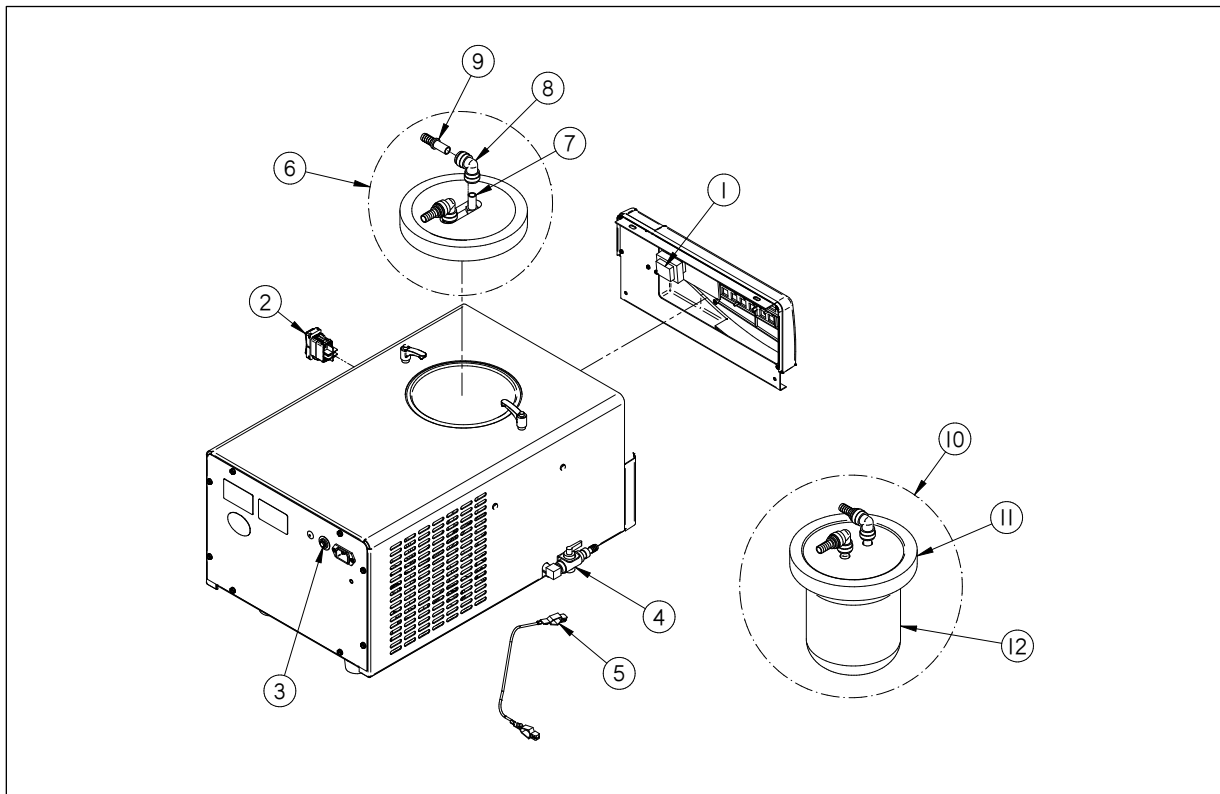

Cold Trap -84 Models

Table A-2

Item	Quantity Required	Catalog Number	Description
1	1	7394402	Circuit Board
2	1	1307400	Switch
3	1	1327207	Circuit Breaker (115V)
3A	2	1327208	Circuit Breaker (230V)
4	1	1360500	Valve
5	1	7464600	Ground Wire Assembly
6	1	7386701	Lid Assembly Stainless Steel (Complete)
7	2	1554900	Elbow
8	2	1554700	Stem
9	1	7397605	Glass Trap Assembly (Complete) Optional
10	1	7397606	Glass Trap Lid Assembly
11	1	7871500	Glass Trap
12	1	7474200	Timer, 6 Minute Delay (115V)
12A	1	7474400	Timer, 6 Minute Delay (230V)
13	1	7515300	Temperature Sensor (not shown)

Figure A-2

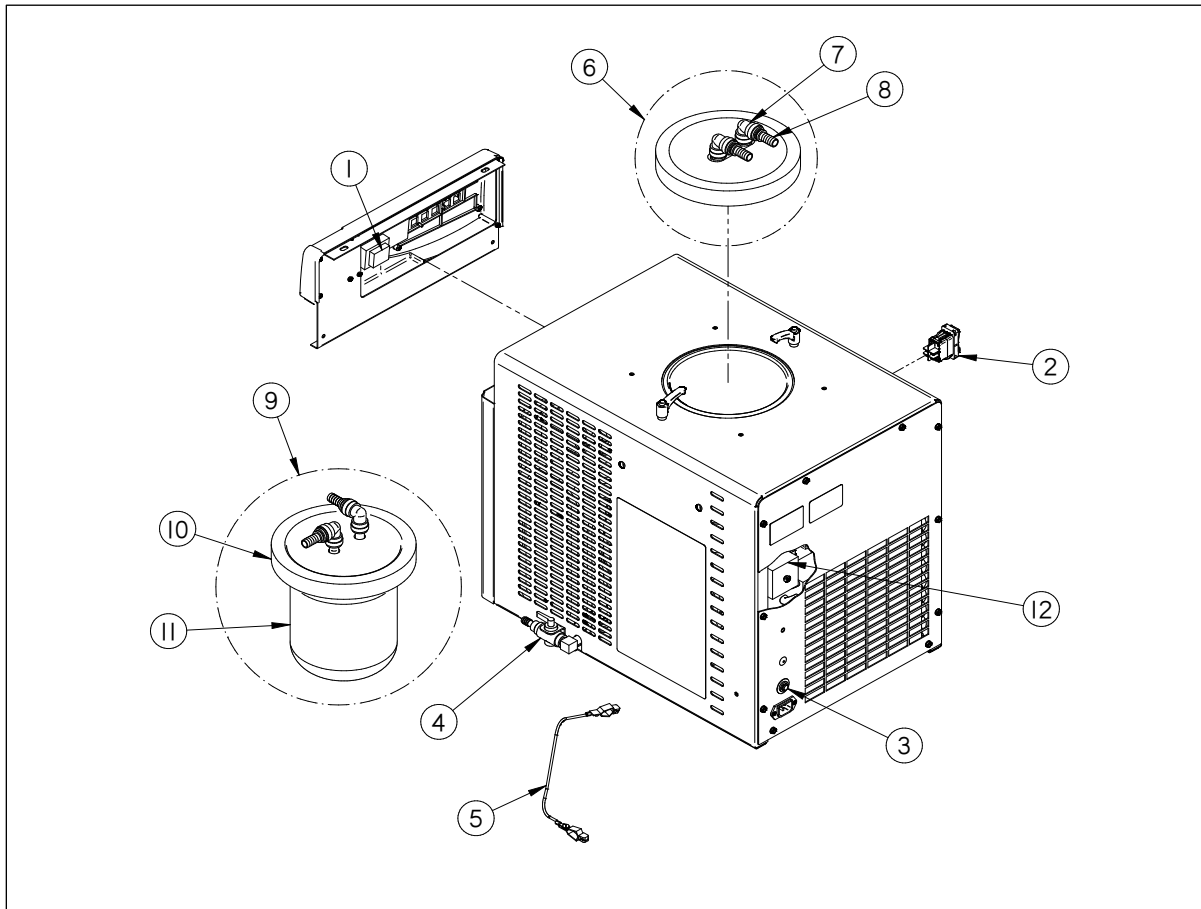

Cold Trap -105 Models

Table A-3

Item	Quantity Required	Catalog Number	Description
1	1	7394402	Circuit Board
2	1	1307400	Switch
3	1	1289315	Circuit Breaker (115V)
3A	2	1289308	Circuit Breaker (230V)
4	1	1360500	Valve
5	1	7464600	Ground Wire Assembly
6	1	7386701	Lid Assembly Stainless Steel (Complete)
7	2	1554900	Elbow
8	2	1554700	Stem
9	1	7397605	Glass Trap Assembly (Complete) Optional
10	1	7397606	Glass Trap Lid Assembly
11	1	7871500	Glass Trap
12	1	7474200	Timer, 6 Minute Delay (115V)
12A	1	7474400	Timer, 6 Minute Delay (230V)
13	1	7480000	Timer, ON/OFF Recycle (115V)
13A	1	7480001	Timer, ON/OFF Recycle (230V)
14	1	7515300	Temperature Sensor (not shown)

Figure A-3

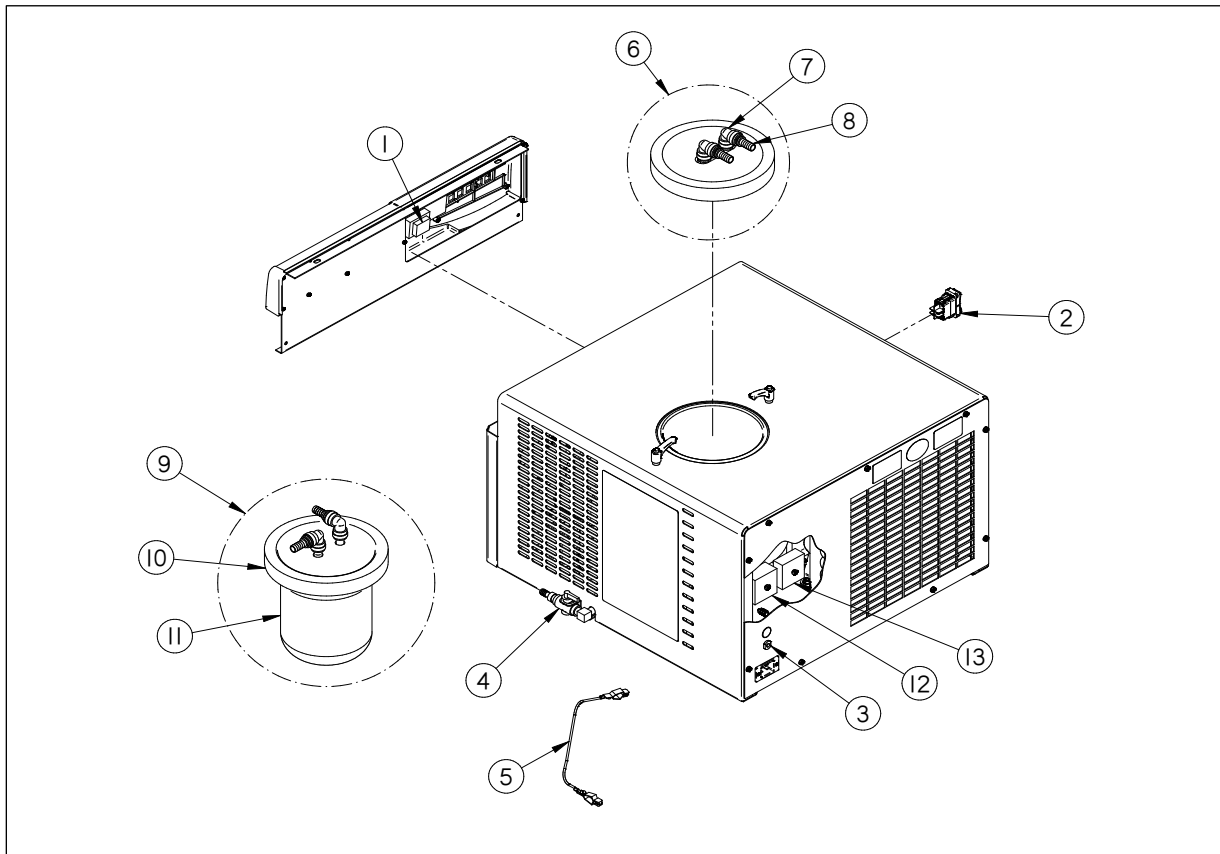

Appendix B: Dimensions

Figure B-1 illustrates the product dimensions for Cold Trap -50 Models

Figure B-1

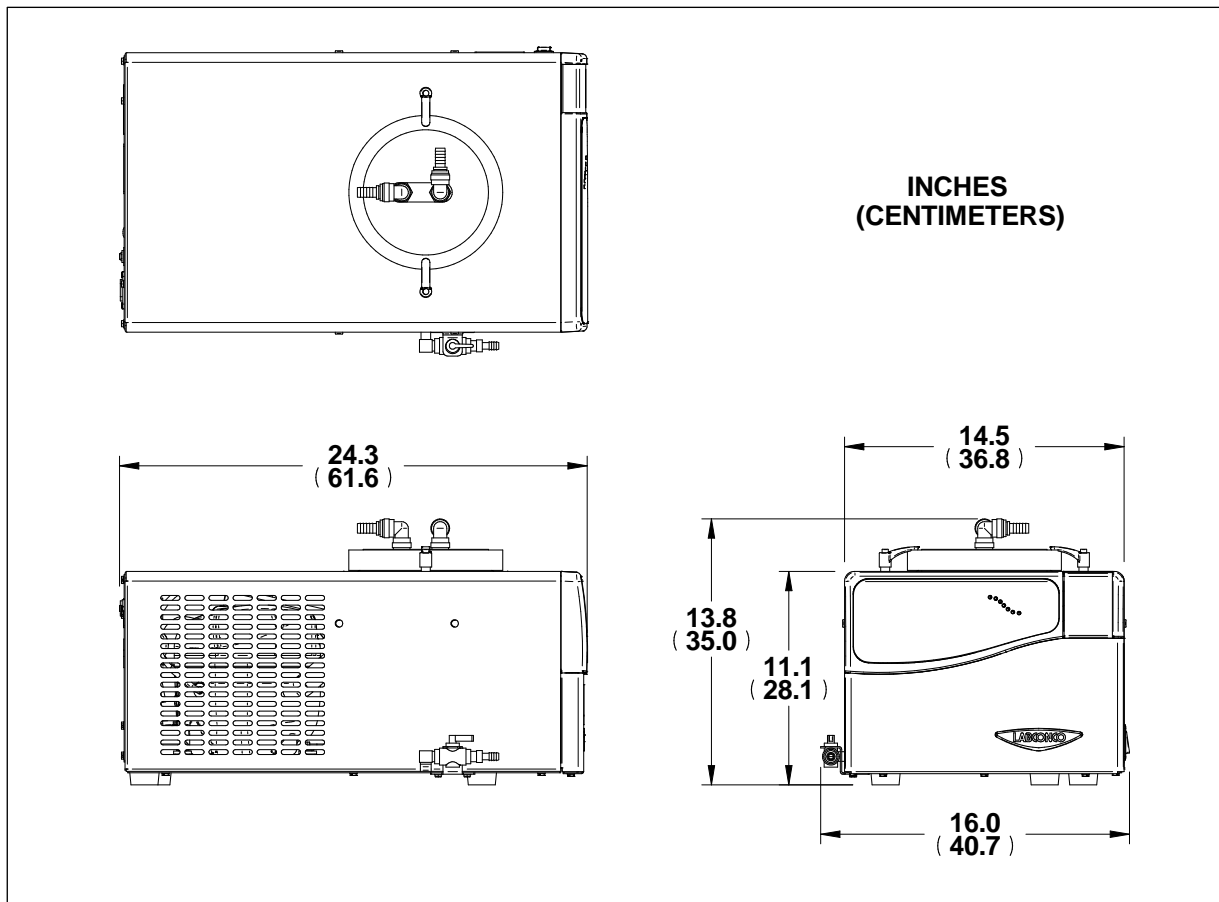

Figure B-2 illustrates the product dimensions for Cold Trap -84 Models

Figure B-2

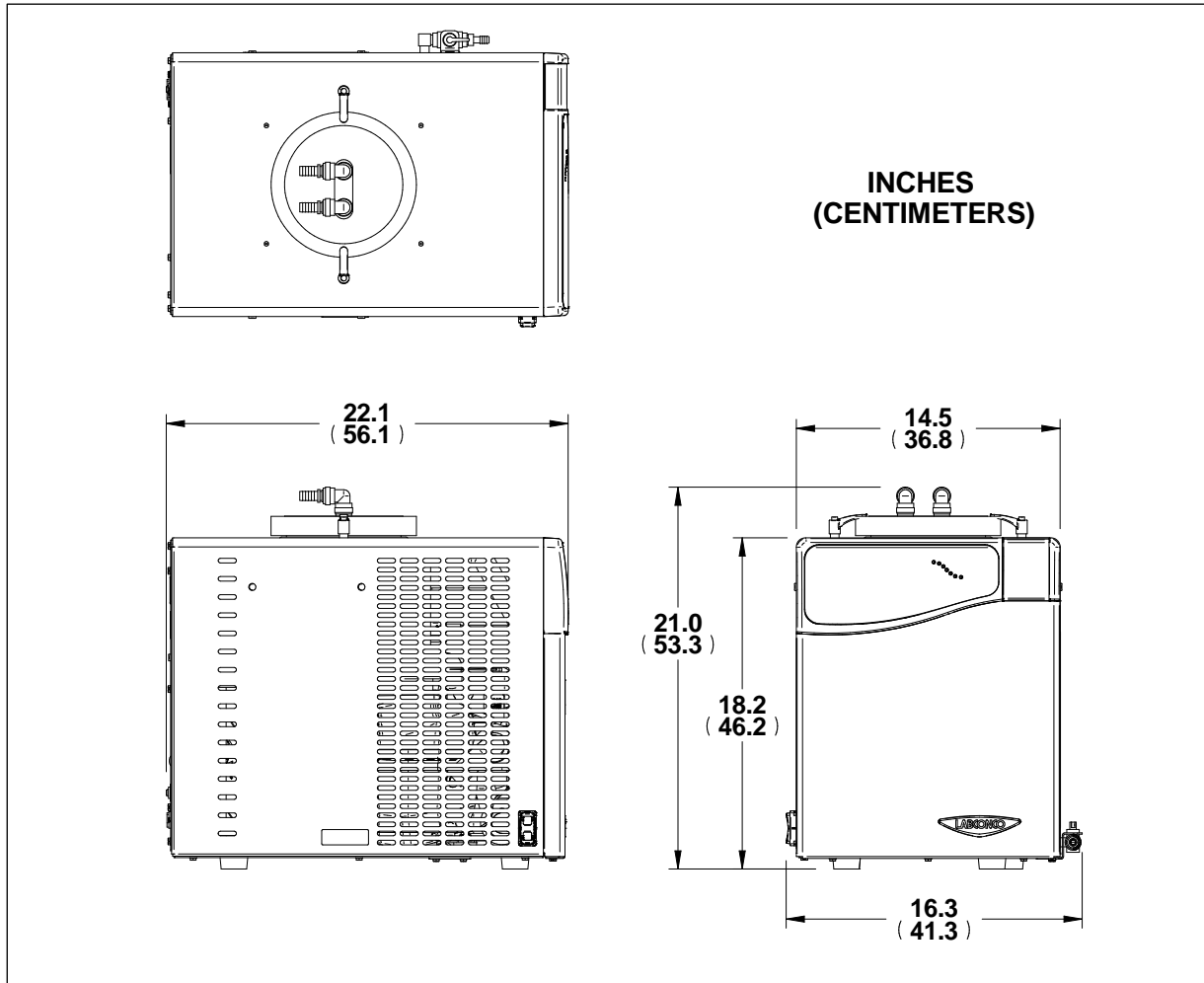
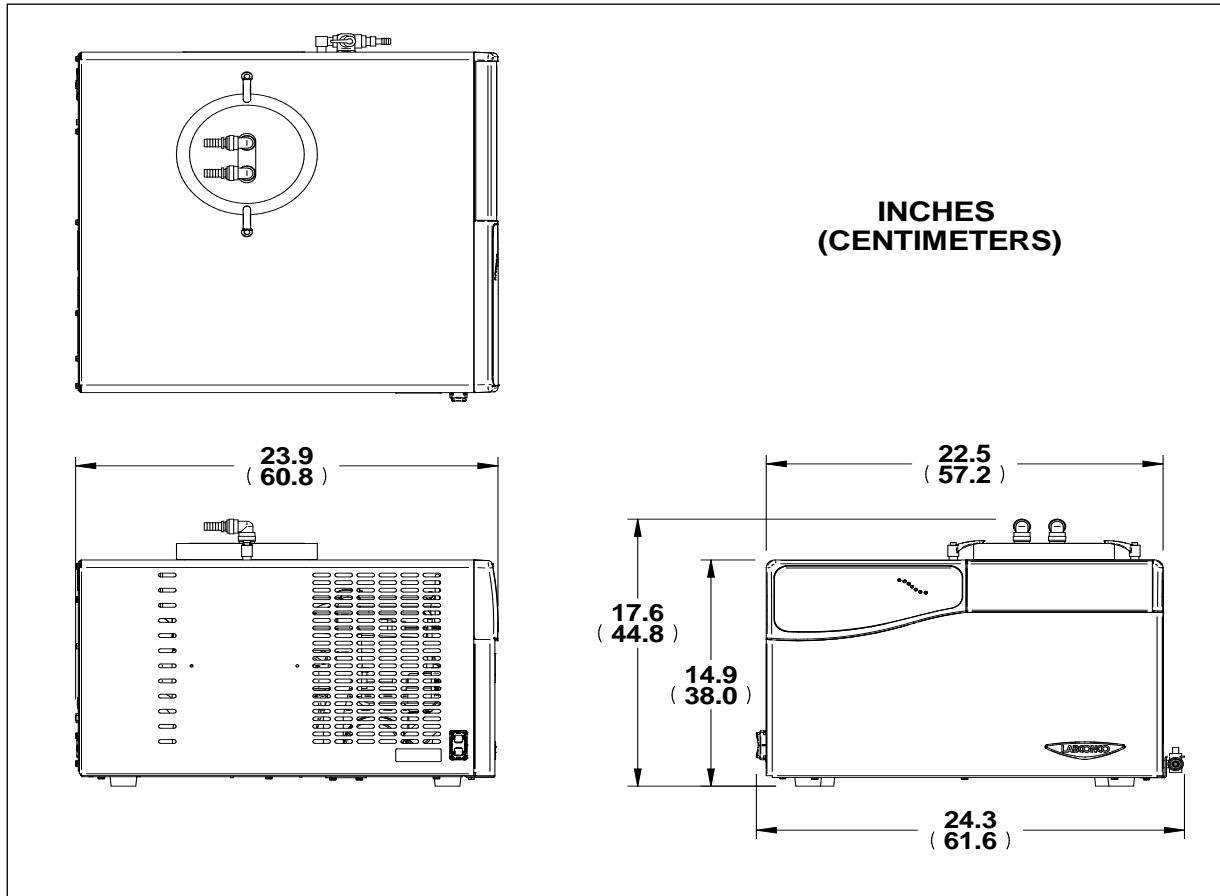

Figure B-3 illustrates the product dimensions for Cold Trap -105 Models

Figure B-3



Appendix C: Specifications

Power Data

Table C-1

Catalog Number	Normal Operating Power (Watts)
86010xx	280 W
86111xx	650 W
86211xx	700 W

Environmental Conditions

- Indoor use only
- Ambient temperature range: 41° to 104°F (5° to 40°C)
- Maximum relative humidity: 80% for temperatures up to 88°F (31°C), decreasing linearly to 50% relative humidity at 104°F (40°C)
- Main supply voltage fluctuations not to exceed $\pm 10\%$ of the nominal voltage
- Transient overvoltages according to Installation Categories II (Overvoltage Categories per IEC 1010). Temporary voltage spikes on the AC input line that may be as high as 1500V for 115V models and 2500V for 230V models are allowed
- Used in an environment of Pollution degrees 2 (i.e., where normally only non-conductive atmospheres are present). Occasionally, however, a temporary conductivity caused by condensation must be expected, in accordance with IEC 664

